



# HSS

## OPERATOR'S MANUAL

---

■ 1.110-604.0

■ 1.110-605.0

■ 1.110-606.0

■ 1.110-607.0

■ 1.110-616.0

■ 1.110-617.0

■ 1.110-618.0

■ 1.110-619.0

---

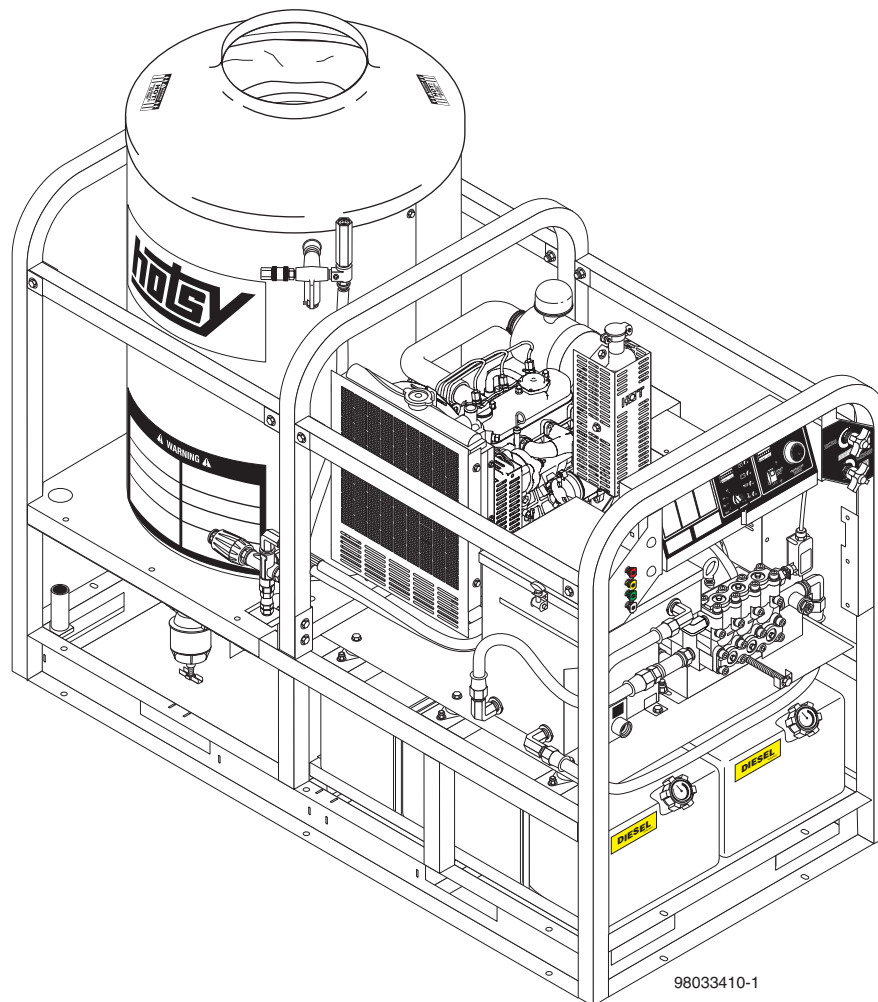

---

For technical assistance or the dealer nearest you,  
consult our web page at [www.hotsy.com](http://www.hotsy.com)



# CONTENTS

---

Introduction and Important Safety Information	5-7
Component Identification	8
Assembly Instructions	9
Operating Instructions	10-11
Detergents and Cleaning Tips	12
Shut Down, Clean-Up and Storage	13
Maintenance	14-17
Troubleshooting	18-21

Model Number \_\_\_\_\_

Serial Number \_\_\_\_\_

Date of Purchase \_\_\_\_\_

The model and serial numbers will be found on a decal attached to the pressure washer. You should record both serial number and date of purchase and keep in a safe place for future reference.

# SYMBOLS

## Identification of Operational Label Symbols



**Hour Meter**



**Pump Switch**



**Burner Switch**



**Steam Combination**



**Detergent**

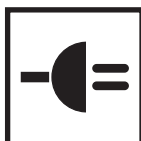

**Voltage**

When the light is on, it means the power supply is on



**Temperature**

When the light is on, it means the engine is overheating.  
Turn machine off and perform maintenance.



**Glow Plug**

When the light is on the engine is being pre-heated.  
When the light turns off the engine can be started.



**Low Oil**

When the light is on, it means check the oil level.  
Add oil if needed.



**Battery is Not Charging**

When the light is on, it means check battery and/or  
charging system.

# INTRODUCTION & IMPORTANT SAFETY INFORMATION

Thank you for purchasing this Pressure Washer.

We reserve the right to make changes at any time without incurring any obligation.

## Owner/User Responsibility:

The owner and/or user must have an understanding of the manufacturer's operating instructions and warnings before using this pressure washer. Warning information should be emphasized and understood. If the operator is not fluent in English, the manufacturer's instructions and warnings shall be read to and discussed with the operator in the operator's native language by the purchaser/owner, making sure that the operator comprehends its contents.

Owner and/or user must study and maintain for future reference the manufacturers' instructions.

The operator must know how to stop the machine quickly and understand the operation of all controls. Never permit anyone to operate the engine without proper instructions.

## SAVE THESE INSTRUCTIONS

This manual should be considered a permanent part of the machine and should remain with it if machine is resold.

When ordering parts, please specify model and serial number. Use only identical replacement parts.

**This machine is to be used only by trained operators.**

## IMPORTANT SAFETY INFORMATION

**! WARNING**



READ OPERATOR'S MANUAL THOROUGHLY PRIOR TO USE.

**WARNING:** To reduce the risk of injury, read operating instructions carefully before using.

1. Read the owner's manual thoroughly. Failure to follow instructions could cause malfunction of the machine and result in death, serious bodily injury and/or property damage.
2. Know how to stop the machine and bleed pressure quickly. Be thoroughly familiar with the controls.
3. Stay alert — watch what you are doing.

**! DANGER**



KEEP WATER SPRAY AWAY FROM ELECTRICAL WIRING.

**DANGER:** Keep wand, hose, and water spray away from electric wiring or fatal electric shock may result.

4. All installations must comply with local codes. Contact your electrician, plumber, utility company or the selling distributor for specific details.

**! WARNING**



EAR PROTECTION MUST BE WORN

**WARNING:** This machine exceeds 85 db appropriate ear protection must be worn.

**! WARNING**



USE PROTECTIVE EYE WEAR AND CLOTHING WHEN OPERATING THIS EQUIPMENT.

**WARNING:** High pressure spray can cause paint chips or other particles to become airborne and fly at high speeds. To avoid personal injury, eye, hand and foot safety devices must be worn.

5. Eye, hand, and foot protection must be worn when using this equipment.

6. Keep operating area clear of all persons.

**! WARNING**



RISK OF EXPLOSION: OPERATE ONLY WHERE OPEN FLAME OR TORCH IS PERMITTED

**WARNING:** Flammable liquids can create fumes which can ignite, causing property damage or severe injury.

**WARNING:** Risk of explosion — Operate only where open flame or torch is permitted.

**! WARNING**



RISK OF FIRE. DO NOT ADD FUEL WHEN OPERATING MACHINE.

**WARNING:** Risk of fire — Do not add fuel when the product is operating or still hot.

**WARNING:** Do not use gasoline, crankcase draining or oil containing gasoline, solvents or alcohol. Doing so will result in fire and/or explosion.

**WARNING:** Risk of fire — Do not spray flammable liquids.

7. Allow engine to cool for 1-2 minutes before refueling. If any fuel is spilled, make sure the area is dry before starting the engine. (Fire and/or explosion may occur if this is not done.)

Engines on mobile or portable equipment shall be refueled:

- a. outdoors;
- b. with the engine on the equipment stopped;
- c. with no source of ignition within 10 feet of the dispensing point; and
- d. with an allowance made for expansion of the fuel should the equipment be exposed to a higher ambient temperature.

## IMPORTANT SAFETY INFORMATION

In an overfilling situation, additional precautions are necessary to ensure that the situation is handled in a safe manner.

**WARNING: Risk of injury. Disconnect battery ground terminal before servicing.**

8. When in use, do not place machine near flammable objects as the engine is hot.
9. Oil burning appliances shall be installed only in locations where combustible dusts and flammable gases or vapors are not present. Do not store or use flammable materials near this machine.
10. Use diesel fuels specified to (ASTM D975) grade #1 or #2 only. **NEVER** use gasoline in your fuel oil tank. Gasoline is more combustible than fuel oil and could result in a serious explosion. **NEVER** use crankcase or waste oil or malfunction could result from contamination.

**WARNING**



RISK OF INJURY. HOT SURFACES CAN CAUSE BURNS

**WARNING: Risk of injury. Hot surfaces can cause burns. Use only designated gripping areas of spray gun and wand. Do not place hands or feet on non-insulated areas of the pressure washer.**

11. Transport/Repair with fuel tank EMPTY or with fuel shut-off valve OFF.

**CAUTION**



HOT DISCHARGE FLUID: DO NOT TOUCH OR DIRECT DISCHARGE STREAM AT PERSONS.

**CAUTION: Hot discharge fluid. Do not touch or direct discharge stream at persons.**

**WARNING: This machine produces hot water and must have insulated components attached to protect the operator.**

12. To reduce the risk of injury, close supervision is necessary when a machine is used near children. Do not allow children to operate the pressure washer. **This machine must be attended during operation.**

**WARNING**



TRIGGER GUN KICKS BACK - HOLD WITH BOTH HANDS

**WARNING: Grip cleaning wand securely with both hands before starting. Failure to do this could result in injury from a whipping wand.**

13. Never make adjustments on machine while in operation.

14. Be certain all quick coupler fittings are secured before using pressure washer.

**WARNING**



RISK OF INJECTION OR SEVERE INJURY TO PERSONS. KEEP CLEAR OF NOZZLE.

**WARNING: High pressure developed by these machines will cause personal injury or equipment damage. Keep clear of nozzle. Use caution when operating. Do not direct discharge stream at people, or severe injury or death will result.**

**WARNING**



PROTECT FROM FREEZING

**WARNING: Protect machine from freezing.**

15. To keep machine in best operating conditions, it is important you protect machine from freezing. Failure to protect machine from freezing could cause malfunction of the machine and result in death, serious bodily injury, and/or property damage. Follow storage instructions specified in this manual.

**WARNING**



RISK OF ASPHYXIATION. USE THIS PRODUCT ONLY IN A WELL VENTILATED AREA.

16. Inlet water must be clean fresh cold water supply.

**WARNING: Risk of asphyxiation. Use this product only in a well ventilated area.**

17. Avoid installing machines in small areas or near exhaust fans. Adequate oxygen is needed for combustion or dangerous carbon monoxide will result.

18. Manufacturer will not be liable for any changes made to our standard machines or any components not purchased from us.

19. The best insurance against an accident is precaution and knowledge of the machine.

**WARNING**



RISK OF INJURY FROM FALLS WHEN USING LADDER.

**WARNING: Be extremely careful when using a ladder, scaffolding or any other relatively unstable location. The cleaning area should have adequate slopes and drainage to reduce the possibility of a fall due to slippery surfaces.**

## IMPORTANT SAFETY INFORMATION

20. Do not allow acids, caustic or abrasive fluids to pass through the pump and heating oil.
21. Never run pump dry or leave spray gun closed longer than 1-2 minutes.
22. Machines with shut-off spray gun should not be operated with the spray gun in the off position for extensive periods of time as this may cause damage to the pump.
23. Protect discharge hose from vehicle traffic and sharp objects. Inspect condition of high pressure hose before using or bodily injury may result.
24. Before disconnecting discharge hose from water outlet, turn burner off and open spray gun to allow water to cool below 100°F before stopping the machine. Failure to properly cool down the heating coil may result in damage. Turn off engine then open spray gun to relieve pressure before removing hose assembly.
25. Do not overreach or stand on unstable support. Keep good footing and balance at all times.
26. Do not operate this machine when fatigued or under the influence of alcohol, prescription medications, or drugs.
27. Use diesel fuels specified to (ASTM D975) grade #1 or #2 only. Bio fuel is restricted to B5 grade only (5%).
28. While loading this machine onto a truck or trailer caution must be observed to prevent personal injury or equipment damage.



Follow the maintenance instructions specified in the manual.

# COMPONENT IDENTIFICATION

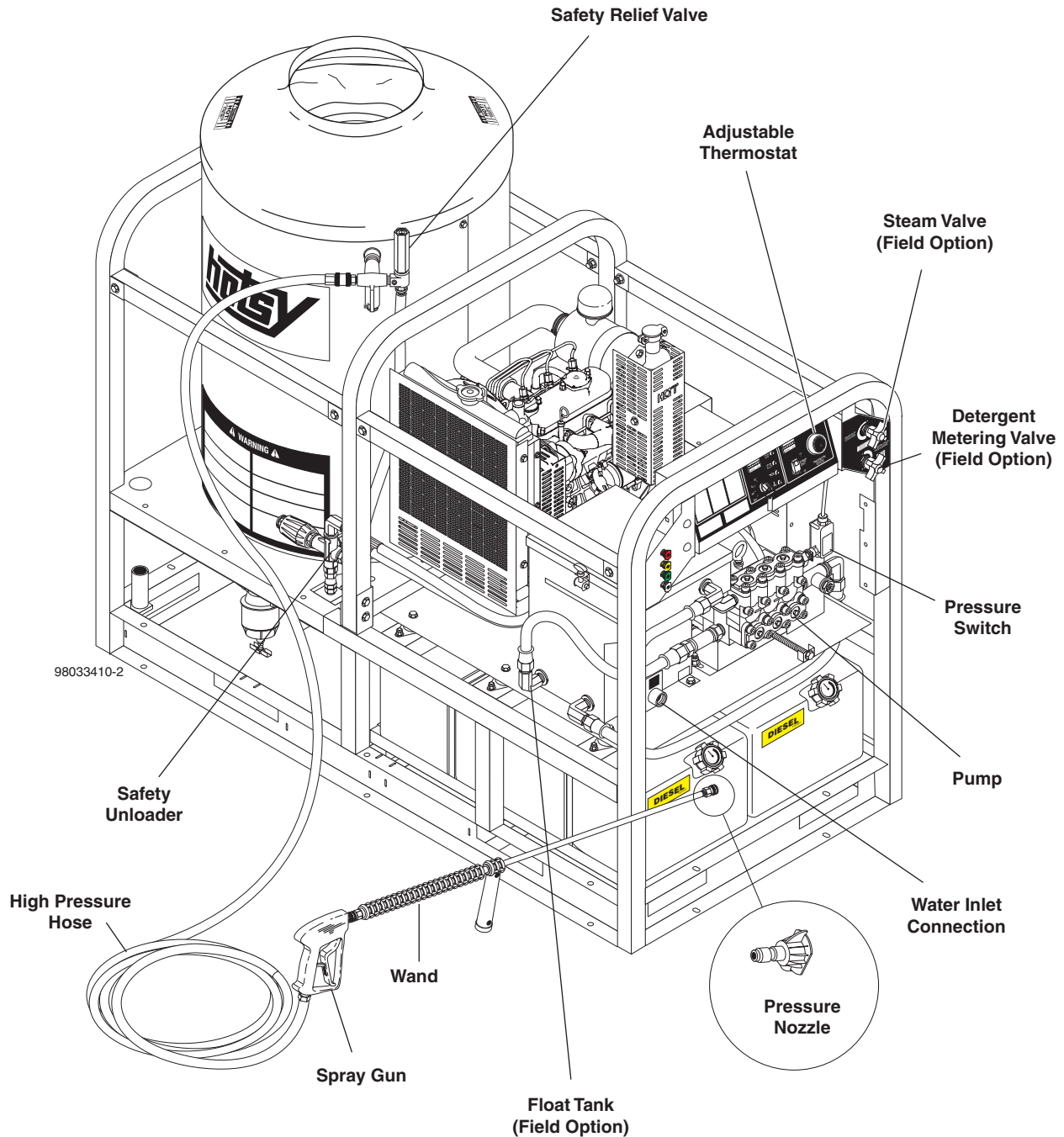

**Pump** — Develops high pressure by pumping water volume through nozzle.

**Spray Gun** — Controls the application of water and detergent onto cleaning surface with trigger device. Includes safety latch.

**Detergent Metering Valve** — Controls detergent mixture.

**Wand** — Must be connected to the spray gun.

**Safety Relief Valve** — Prevents over pressurization

**Safety Unloader** — By-passes the high pressure to low pressure when spray gun is closed.

**High Pressure Hose** — Connect one end to water pump discharge nipple and the other end to spray gun.

**Pressure Nozzle** — Inserted into wand quick coupler to develop pressure

**Adjustable Thermostat** — Prevents water temperature from exceeding high temperatures. Is not used to maintain constant temperature setting.

**Pressure switch** — Turns off burner when spray gun is closed.



# ASSEMBLY INSTRUCTIONS

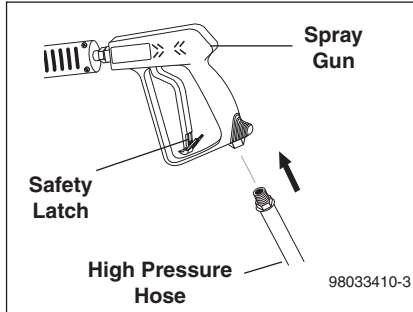

**STEP 1:** Attach the high pressure hose to the spray gun using teflon tape on hose threads.

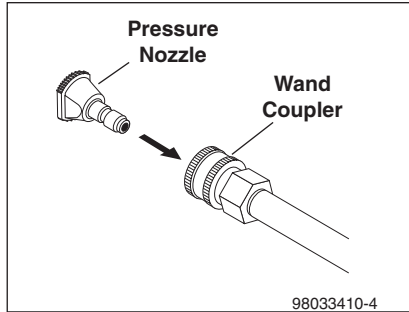

**STEP 2:** Pull the spring-loaded collar of the wand coupler back to insert your choice of pressure nozzle.

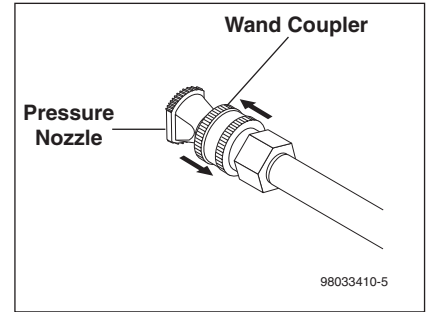

**STEP 3:** Release the coupler collar and push the nozzle in until the collar clicks. Pull the nozzle to make sure it is seated properly.

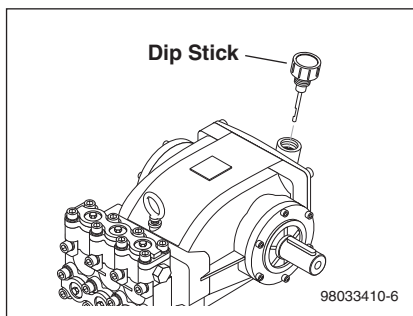

**STEP 4:** Remove shipping cap and install oil dipstick. Check pump oil level by using dipstick or observe oil level in oil window (if equipped). Use 10W-40 non detergent pump oil.

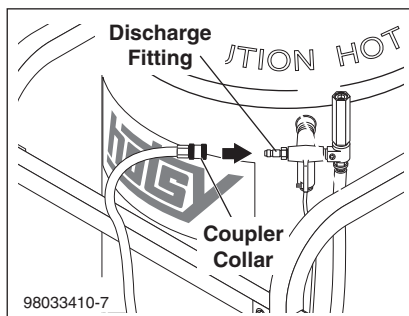

**STEP 5:** Connect the high pressure hose to the pump discharge fitting. Push coupler collar forward until secure.

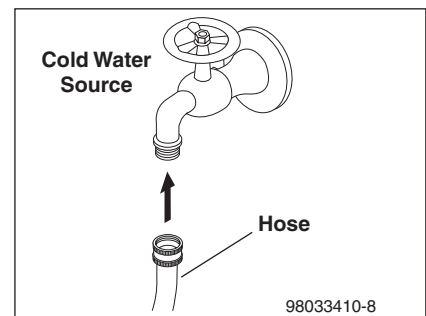

**STEP 6:** Connect one end of hose to the cold water source.

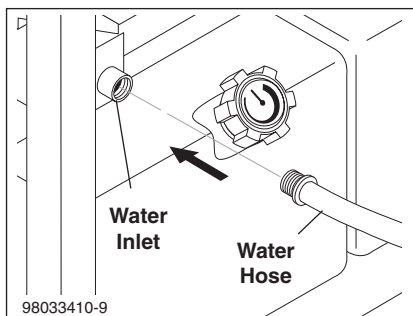

**STEP 7:** Connect the other end of the water hose to pump water inlet. Inspect inlets. **CAUTION: Do not run the pump without water or pump damage will result.**

# OPERATING INSTRUCTIONS

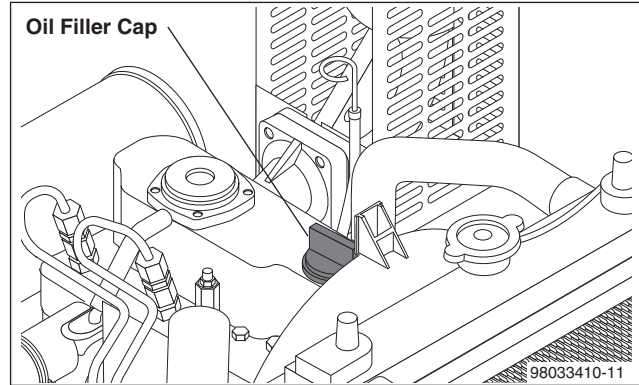
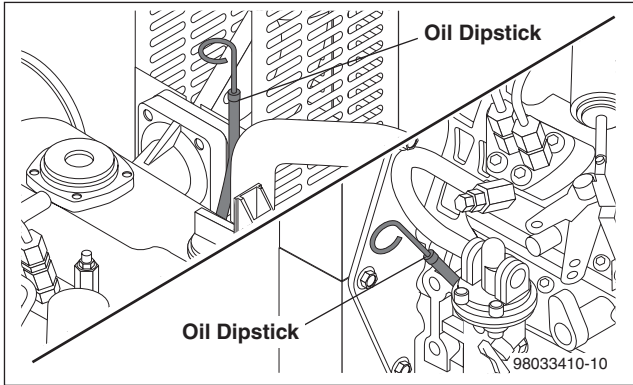

**STEP 1:** Check engine oil level. Oil level should be between the lines on the dipstick. (Refer to the engine's operating manual included with machine.) We recommend that the oil be changed after the first 5 hours of use, then once every 50 hours. **NOTE:** Improper oil levels will cause low oil sensor to shut off engine. **IMPORTANT!** Do not run engine with high or low oil levels as this will cause engine damage.

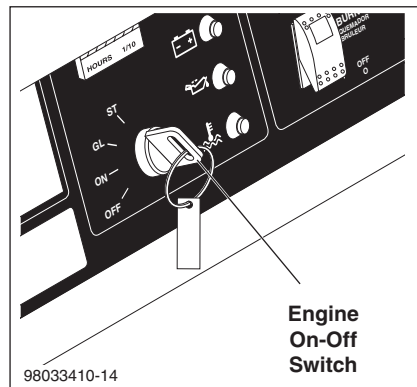
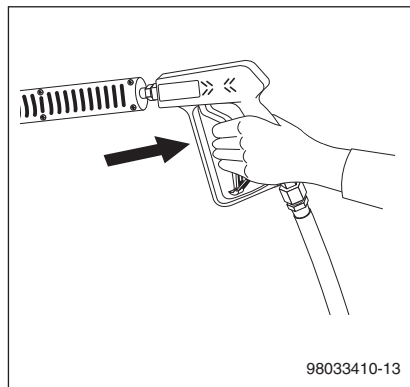
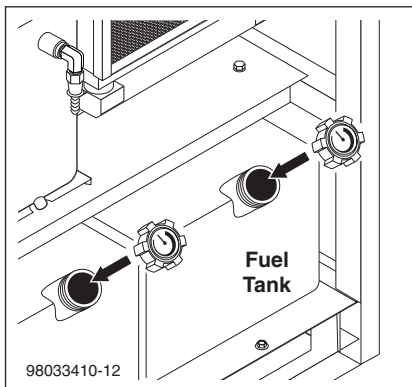

**STEP 2:** Fill engine/burner fuel tanks with fuel.

**STEP 3:** Before installing nozzle, trigger the spray gun to eliminate trapped air then wait for a steady flow of water to emerge from the wand coupler when engine starts. Run machine allowing water to flush through the system until clear.

**STEP 4:** Read engine operators manual before starting. Turn the key to GL (Glow Plug) and wait for light to go out. Turn the engine switch to ST (Start) position.

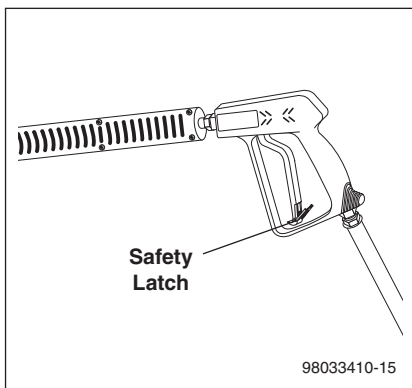

**WARNING!** Never replace nozzles without engaging the safety latch on the spray gun trigger.

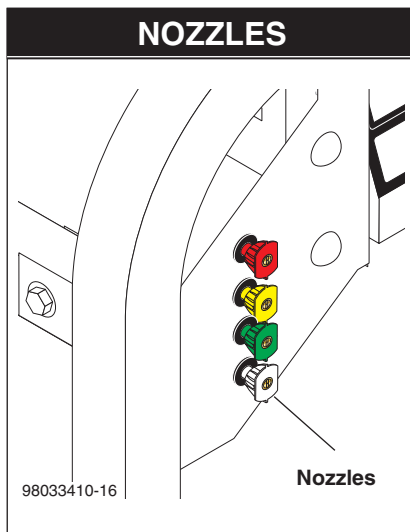

The quick connect nozzles provide a wide array of spray widths from 0° to 40° and are easily accessible when placed in the convenient rubber nozzle holder, which is provided on the front of the machine.

**NOTE:** For a more gentle rinse, select the white 40° or green 25° nozzle. To scour the surface, select the yellow 15° or red 0° nozzle.

## STEAM COMBINATION (FIELD INSTALLATION)

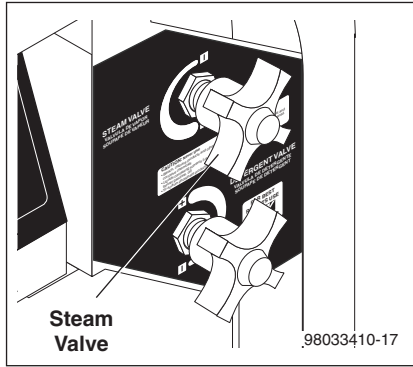

**Step 1:** For steam, open the steam valve counterclockwise.

This lowers the pressure and raises the temperature.

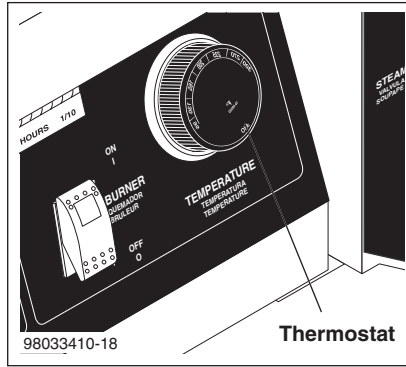

**Step 2:** Turn the thermostat knob to the 270° mark, (The thermostat is a high limit device and does not regulate temperature).

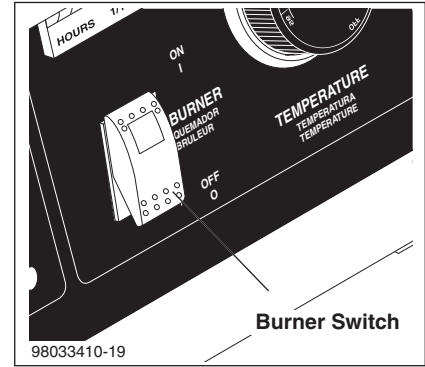

**Step 3:** To stop, reverse steps and set all controls to their original settings.

**Step 4:** Turn burner switch off, open trigger on spray gun and allow water to cool below 100°.

# APPLYING DETERGENTS & GENERAL CLEANING TECHNIQUES



**WARNING:** Some detergents may be harmful if inhaled or ingested, causing severe nausea, fainting or poisoning. The harmful elements may cause property damage or severe injury.

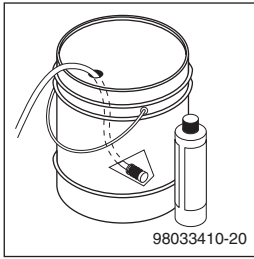

**STEP 1:** Use detergent designed specifically for pressure washers. Household detergents could damage the pump. Prepare detergent solution as required by the manufacturer. Fill a container with pressure washer detergent. Place the filter end of detergent suction tube into the detergent container.

**STEP 2:** Open detergent valve knob to desired mixture ratio.

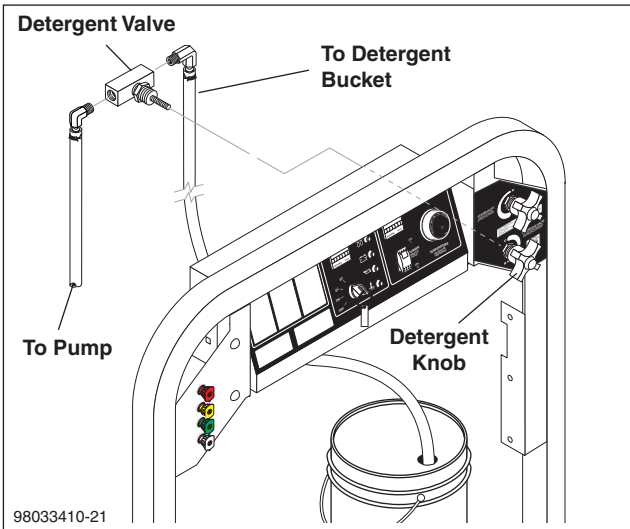

**STEP 3:** With the engine running, pull trigger to operate machine. Liquid detergent is drawn into the machine and mixed with water. Apply detergent to work area. Do not allow detergent to dry on surface.

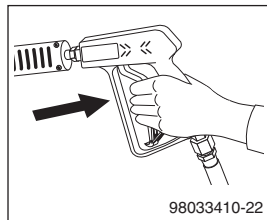

**IMPORTANT:** You must flush the detergent line after each use by placing the suction tube into a bucket of clean water, then run the pressure washer for 1-2 minutes.

## THERMAL PUMP PROTECTION

If you run the engine on your pressure washer for 3-5 minutes without pressing the trigger on the spray gun, circulating water in the pump can reach high temperatures. When the water reaches this temperature, the pump protector engages and cools the pump by discharging the warm water onto the ground. This thermal device prevents internal damage to the pump.

## CLEANING TIPS

Pre-rinse cleaning surface with fresh water. Place detergent suction tube directly into cleaning solution and apply to surface (for best results, limit your work area to sections approximately 6 feet square and always apply detergent from bottom to top). Allow detergent to remain on surface 1-3 minutes. Do not allow detergent to dry on surface. If surface appears to be drying, simply wet down surface with fresh water. If needed, use brush to remove stubborn dirt. Rinse from top to bottom in an even sweeping motion keeping the spray nozzle approximately 1 foot from cleaning surface. Use overlapping strokes as you clean and rinse any surface. For best surface cleaning action spray at a slight angle.

### Recommendations:

- Before cleaning any surface, an inconspicuous area should be cleaned to test spray pattern and distance for maximum cleaning results.
- If painted surfaces are peeling or chipping, use extreme caution as pressure washer may remove the loose paint from the surface.
- Keep the spray nozzle a safe distance from the surface you plan to clean. High pressure wash a small area, then check the surface for damage. If no damage is found, continue to pressure wash.

### CAUTION - Never use:

- Bleach, chlorine products and other corrosive chemicals
- Liquids containing solvents (i.e., paint thinner, gasoline, oils)
- Tri-sodium phosphate products
- Ammonia products
- Acid-based products

These chemicals will harm the machine and will damage the surface being cleaned.

## RINSING

It will take a few seconds for the detergent to clear. Apply safety latch to spray gun. Open detergent valve. Select and install the desired high pressure nozzle.

## SHUTTING DOWN AND CLEAN-UP

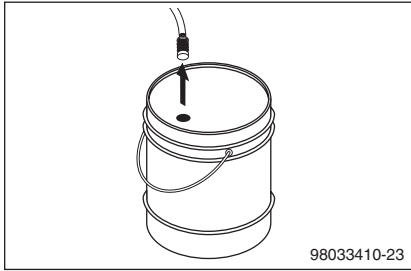

**STEP 1:** Remove detergent suction tube from container and insert into one gallon of fresh water. Open detergent mixing valve. Pull trigger on spray gun and siphon water for one minute.

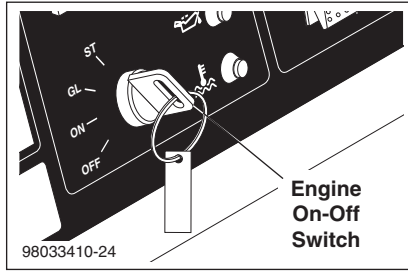

**STEP 2:** Turn key to stop position. Engine shuts down by way of solenoid.

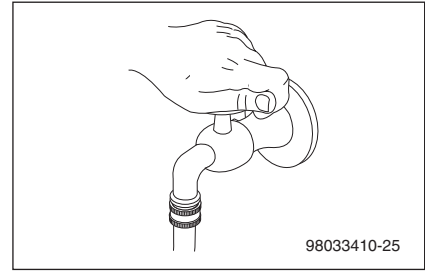

**STEP 3:** Turn off water supply.

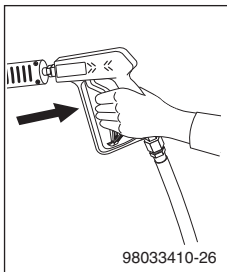

**STEP 4:** Press trigger to release water pressure.

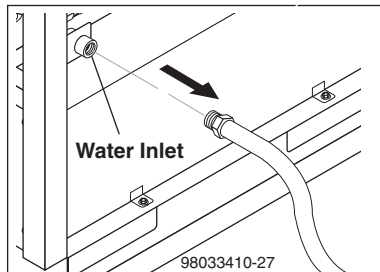

**STEP 5:** Disconnect the water supply from the water inlet on the machine.

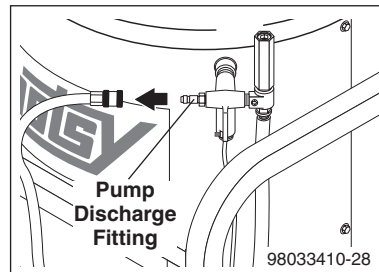

**STEP 6:** Disconnect the high pressure hose from pump discharge fitting.



**STEP 7:** Engage the spray gun safety lock.

## STORAGE

Measures should be taken to protect your Kubota diesel engine if the engine is not operated for a period of 30 days or more. Proper storage will protect the engine from corrosion and prevent costly repairs due to storage induced problems.

### Storage - 1 to 6 months

1. Start and idle the engine at a no-load condition for 15 minutes.
2. Stop the engine, allow the engine to cool enough to safely drain the oil. Re-install the oil drain plug, then fill the crankcase with MIL-L-644-P9 protectant oil. Fill the fuel tank with a high grade fuel preservative (add mix) such as STA-BIL per the manufacturer recommendations.
3. Start and operate the engine at 3/4 speed for 5-10 minutes.
4. Stop the engine, allow to cool enough to safely drain the engine oil as shown. Re-install the oil drain plug.
5. Refill the engine with standard recommended lubricating oil.
6. Drain the fuel tank. Remove the fuel filter. Install a new fuel filter.
7. Carefully clean all debris from the radiator fins.
8. Spray the inside of the exhaust manifold with SAE 10W oil.
9. Cover all openings with tape and apply grease to any and all unpainted surfaces.
10. Loosen the fan belt before wrapping the engine in plastic film and storing in a dry place away from high voltage sources and off the ground.

### Storage - In excess of 6 months

Perform the storage preparation procedures above except with the following changes.

1. Replace the engine oil in step 2 above with MIL-L-21260, grade 2, SAE 30W rustproof oil.
2. Coat any and all unpainted surfaces with MIL-C 16173D, grade 3 anti-rust grease.
3. Replace anti-freeze every 2 years.

## MAINTENANCE

### PREVENTATIVE MAINTENANCE

1. Check to see that water pump is properly lubricated.
2. Follow winterizing instructions to prevent freeze damage to pump and coils.
3. Always neutralize and flush detergent from system after use.
4. If water is known to have high mineral content, use a water softener in your water system, or de-scale as needed.
5. Do not allow acidic, caustic or abrasive fluids to be pumped through system.
6. Always use high grade quality cleaning products.
7. Never run pump dry for extended periods of time.
8. Use clean fuel and replace fuel filter every 100 hours of operation. Avoid water contaminated fuel as it will damage the fuel pump.
9. If machine is operated with smoky or eye burning exhaust, coils will soot up, not letting water reach maximum operating temperature.
10. Never allow water to be sprayed on or near the engine or burner assembly or any electrical component.
11. Periodically delime coils as per instructions.
12. Check to see that engine is properly lubricated.

It is advisable, periodically, to visually inspect the burner. Check air inlet to make sure it is not clogged or blocked. Wipe off any oil spills and keep equipment clean and dry.

The flow of combustion and ventilating air to the burner must not be blocked or obstructed in any manner.

The area around the washer should be kept clean and free of combustible materials, gasoline and other flammable vapors and liquids.

### MAINTENANCE & SERVICE

#### Unloader Valves:

Unloader valves are preset and tested at the factory before shipping. Tampering with the factory setting may cause personal injury and/ or property damage and will void the manufacturer's warranty.

#### Winterizing Procedure:

Damage due to freezing is not covered by warranty. Adhere to the following cold weather procedures whenever the washer must be stored or operated outdoors under freezing conditions.

During winter months, when temperatures drop below 32°F, protecting your machine against freezing is necessary. Store the machine in a heated room. If this is not

possible then mix a 50/50 solution of anti-freeze and water in the float tank. Turn the engine on to siphon the anti-freeze mixture through the machine. If compressed air is available, an air fitting can be screwed into the float tank by removing the float tank strainer and fitting. Then inject the compressed air. Water will be blown out of the machine when the trigger on the spray gun is opened.

#### High Limit Hot Water Thermostat:

For safety, each machine is equipped with a temperature sensitive high limit control switch. In the event that the water should exceed its operating temperature, the high limit control will turn the burner off until the water cools, then it will automatically reset itself. The thermostat sensor is located on the discharge side of the heating coil. The thermostat control dial is located on the control panel.

#### Pumps:

Use only SAE 10-40 weight non-detergent oil. Change oil after first 50 hours of use. Thereafter, change oil every three months or at 500 hour intervals. Oil level should be checked through use of dipstick found on top of pump, or the red dot visible through the oil gauge window. Oil should be maintained at that level.

#### Cleaning of Coils:

In alkaline water areas, lime deposits can accumulate rapidly inside the heating coil. This growth is increased by the extreme heat build up in the coil. The best prevention for liming conditions is to use high quality cleaning detergents. In areas where alkaline water is an extreme problem, periodic use of Deliming Powder (Part #9.804-059.0) will remove lime and other deposits before coil becomes plugged. (See Deliming instructions for use of Deliming Powder.)

#### Deliming Coils:

Periodic flushing of coils or optional float tank is recommended.

- Step 1 Fill a container with 4 gallons of water, then add 1 lb. of deliming powder. Mix thoroughly. Pour mixture into float tank.
- Step 2 Remove wand assembly from spray gun and put spray gun into float tank. Secure the trigger on the spray gun into the open position.
- Step 3 Turn engine on, allowing solution to be pumped through coils back into the float tank. The solution should be allowed to circulate 2-4 hours or until the color changes.
- Step 4 After circulating solution, flush the entire system with fresh water. Clean out float tank and then reinstall wand assembly to spray gun.

# MAINTENANCE

## Removal of Soot from Heating Coil:

In the heating process, fuel residue in the form of soot deposits may develop between the heating coil pipes, and block air flow which will affect burner combustion. When soot has been detected on visual observation, the soot on the coil must be washed off after following the coil removal steps (See Coil Removal on page 16).

## Relief Valve

**WARNING:** The relief valve on this pressure washer has been factory set and sealed and is a non-field adjustable part. Tampering with the factory setting may cause personal injury and/or property damage and will void the manufacturer warranty. For replacement parts refer to coil outlet assembly exploded views.

## Fuel:

Use clean fuel oil that is not contaminated with water and debris. Replace fuel filter and drain the tank every 100 hours of operation.

Use diesel fuels specified to (ASTM D975) grade #1 or #2 only. **NEVER** use gasoline in your fuel tank. Gasoline is more combustible than fuel oil and could result in a serious explosion. **NEVER** use crankcase or waste oil in your burner. Fuel unit malfunction could result from contamination. Bio fuel is restricted to B5 grade only (5%).

**NOTE:** See Kubota engine manual for fuel recommendations.

## Fuel Control System:

This machine utilizes a fuel solenoid valve located on the fuel pump to control the flow of fuel to the combustion chamber. The solenoid, which is normally closed, is activated by a pressure switch when pump is under load. When the operator releases the trigger on the spray gun, the pump goes into by-pass relieving pressure on the pressure switch turning off the electrical current to the fuel solenoid.

The solenoid then closes, shutting off the supply of fuel to the combustion chamber. Controlling the flow of fuel in this way gives an instantaneous burn-or-no-burn situation, thereby eliminating high and low water temperatures and the combustion smoke normally associated with machines incorporating a spray gun. Periodic inspection, to insure that the fuel solenoid valve functions properly, is recommended. This can be done by operating the machine and checking to see that the burner is not firing when the spray gun is in the OFF position.

## Fuel Pressure Adjustment:

Fuel pressure is factory set to the serial plate. Adjust fuel pressure by turning the regulating pressure adjusting screw clockwise to increase, counterclockwise to decrease. Do not exceed 200 psi. **NOTE:** When chang-

ing fuel pump, a bypass plug must be installed in return port or fuel pump will not prime.

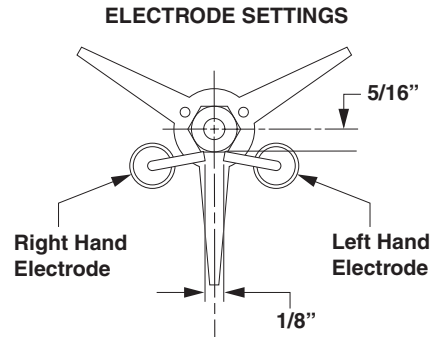

Periodically Check Wiring Connections. If Necessary to adjust electrodes, use diagram.

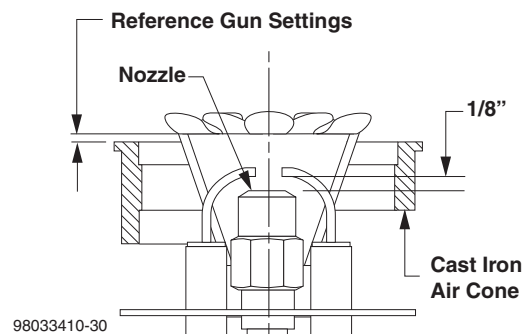

## Burner Gun Setting Instructions: (Wayne EH)

Suggested start-up setting: EH flameblock™ 1/8" ahead of cast iron cone face for 3.00 to 4.00 GPH or 1/4" ahead for 5.00 to 6.00 GPH.

## Burner Nozzle:

Keep the tip free of surface deposits by wiping it with a clean, solvent saturated cloth, being careful not to plug or enlarge the nozzle. For maximum efficiency, replace the nozzle each season.

## Burner Air Adjustment:

The oil burner on this machine is preset for operation at altitudes below 1000 feet. If operated at higher altitudes, it may be necessary to adjust the air band setting. Adjust air band for a #1 or #2 smoke spot on the Bacharach scale. If a smoky or eye-burning exhaust is being emitted from the stack, two things should be checked. First, check the fuel to be certain that diesel fuels specified to (ASTM D975) grade #1 or #2 is being used. Next, check the air adjustment on the burner. An oily, smoky fire indicates a lack of air and the air band should be moved to allow the air to flow through the burner. Sharp eye-burning fumes indicate too much air flowing through the combustion chamber. The air band should be readjusted to allow less air to flow through the burner.

## MAINTENANCE

**CAUTION:** If white smoke appears from burner exhaust vent during start-up or operation, discontinue use and readjust air bands.

**NOTE:** If a flue is installed, have a professional serviceman adjust your burner for a #1 or #2 smoke spot on the Bacharach scale.

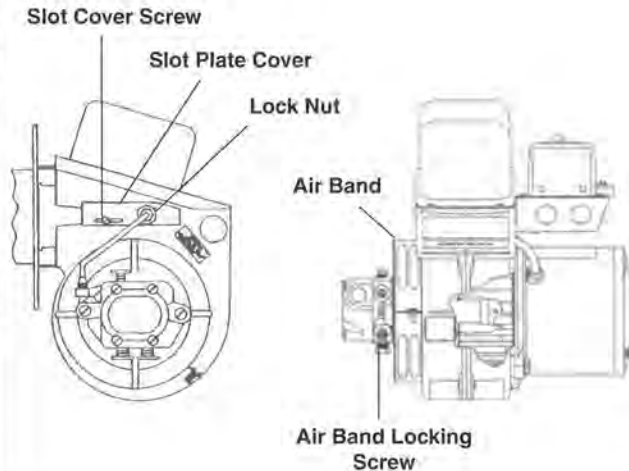

For additional burner component information, see Burner Assembly Exploded View page. It is recommended that the oil burner be serviced yearly or as needed. Contact your local service center.

### Wayne Burner Air Adjustment:

**To adjust,** start the machine and turn burner ON. Loosen locking screw found in the air shutter openings (see illustration) and close air shutter until black smoke appears from burner exhaust vent. Note air band position. Next, slowly open the air shutter until white smoke just starts to appear. Turn air shutter halfway back to the black smoke position previously noted. Tighten locking screws.

### Coil Removal:

Removal of coil because of freeze breakage, or to clean soot from it can be done quickly and easily.

1. Disconnect hose from pump to inlet side of the coil.
2. Carefully disconnect the thermostat sensor making sure you do not crimp the capillary tube.
3. Remove fittings connected to the 1/2" pipe nipples from inlet and discharge sides of coil.
4. Remove nuts holding coil & coil wrap to frame.
5. Remove wrap. Remove coil.
6. Replace or repair any insulation found to be torn or broken.

### Coil Reinstallation:

Reinstall new or cleaned coil reversing steps 6 through 1.



## PREVENTATIVE MAINTENANCE

This pressure washer was produced with the best available materials and quality craftsmanship. However, you as the owner have certain responsibilities for the correct care of the equipment. Attention to regular preventative maintenance procedures will assist in preserving the performance of your equipment. Contact your dealer for maintenance. Regular preventative maintenance will add many hours to the life of your pressure washer. Perform maintenance more often under severe conditions.

**Check** pump oil level before first use of your new pressure washer. **Change** pump oil after first 50 hours and every 3 months or 500 hours thereafter. Use SAE 10-40 weight oil, non-detergent.

### MAINTENANCE

Maintenance Operation		Every 8 Hrs or Daily	25 Hrs or Weekly	50 Hrs or Monthly	100 Hrs or Yearly	Yearly
Check Oil	Pump		x			
	Engine	x				
Change Oil	Pump					x
	Engine			x		
Air Cleaner		Check		Clean		
Spark Plug					x	
Check Valve Clearance						x
Fuel Tank Filter					x	
Water Filter/Clean		Check				x

**NOTE:** Follow Kubota engine manual recommendations in manual provided.

### OIL CHANGE RECORD

Date Oil Changed Month/Day/Year	No. of Operating Hours Since Last Oil Change	Brand Name and Type of Oil (see above)

## TROUBLESHOOTING

PROBLEM	POSSIBLE CAUSE	SOLUTION
<b>LOW OPERATING PRESSURE</b>	Faulty pressure gauge	Install new gauge.
	Insufficient water supply	Use larger supply hose; clean filter at water inlet.
	Old, worn or incorrect spray nozzle	Match nozzle number to machine and/or replace with new nozzle.
	Belt slippage	Tighten or replace; use correct belt.
	Plumbing or hose leak	Check plumbing system for leaks. Re-tape leaks with teflon tape.
	Faulty or mis-adjusted unloader valve	Adjust unloader for proper pressure. Install repair kit when needed.
	Worn packing in pump	Install new packing kit.
	Fouled or dirty inlet or discharge valves in pump	Clean inlet and discharge valves.
	Worn inlet or discharge valves	Replace with valve kit.
	Obstruction in spray nozzle	Remove obstruction.
	Leaking pressure control valve	Rebuild or replace as needed.
	Slow engine RPM	Set engine speed at proper specifications.
	Pump sucking air	Check water supply and possibility of air seepage.
	Valves sticking	Check and clean or replace if necessary.
Unloader valve seat faulty	Check and replace if necessary.	
<b>BURNER WILL NOT LIGHT</b>	Little or no fuel	Fill tank with fuel.
	Improper fuel or water in fuel	Drain fuel tank and fill with proper fuel.
	Clogged fuel line	Clean or replace.
	Plugged fuel filter	Replace as needed.
	Mis-adjusted burner air bands	Readjust air bands for clean burn.
	Little or no fuel pressure from fuel pump	Increase fuel pressure to specification and/or replace fuel pump. Test with pressure gauge.
	Faulty burner transformer	Test transformer for proper arc between contacts. Replace as needed.

## TROUBLESHOOTING

<b>PROBLEM</b>	<b>POSSIBLE CAUSE</b>	<b>SOLUTION</b>
<b>BURNER WILL NOT LIGHT</b> (continued from previous page)	Flex coupling slipping on fuel pump shaft or burner motor shaft	Replace if needed.
	On-Off switch defective	Check for electrical current reaching burner assembly with burner switch on.
	Heavy sooting on coil and burner can cause interruption of air flow and shorting of electrodes	Clean as required.
	Improper electrode setting	Check and reset according to diagram in Operator's Manual.
	Fuel not reaching combustion chamber	Check fuel pump for proper flow. Check solenoid flow switch on machines with spray gun control for proper on-off fuel flow control.
	Clogged burner nozzle	Replace.
	Thermostat faulty or slow engine speed	Increase engine RPM to increase voltage.
	Pressure switch malfunction	Remove, test for continuity and replace as needed.
	Flow solenoid malfunction	Replace if needed.
<b>FLUCTUATING PRESSURE</b>	Valves worn	Check and replace if necessary.
	Blockage in valve	Check and replace if necessary.
	Pump sucking air	Check water supply and air seepage at joints in suction line.
	Worn piston packing	Check and replace if necessary.
<b>MACHINE SMOKES</b>	Improper fuel or water in fuel	Drain tank and replace contaminated fuel.
	Improper air adjustment	Readjust air bands on burner assembly.
	Low fuel pressure	Adjust fuel pump pressure to specifications.
	Plugged or dirty burner nozzle	Replace nozzle.
	Faulty burner nozzle spray pattern	Replace nozzle.
	Heavy accumulation of soot on coils and burner assembly	Remove coils and burner assembly, clean thoroughly.
	Misaligned electrode setting	Realign electrodes to specifications.
	Obstruction in smoke stack	Check for insulation blockage or other foreign objects.

## TROUBLESHOOTING

PROBLEM	POSSIBLE CAUSE	SOLUTION
<b>LOW WATER TEMPERATURE</b>	Improper fuel or water in fuel	Replace with clean and proper fuel.
	Low fuel pressure	Increase fuel pressure.
	Weak fuel pump	Check fuel pump pressure. Replace pump if needed.
	Fuel filter partially clogged	Replace as needed.
	Soot build-up on coils not allowing heat transfer	Clean coils.
	Improper burner nozzle	See burner specifications.
<b>WATER TEMPERATURE TOO HOT</b>	Incoming water to machine warm or hot	Lower incoming water temperature.
	Fuel pump pressure too high	See specifications for proper fuel pressure.
	Fuel pump defective	Replace fuel pump.
	Detergent line sucking air	Tighten all clamps. Check detergent lines for holes.
	Defective temperature switch	Replace.
	Incorrect fuel nozzle size	See burner specifications.
	Insufficient water supplied	Check water G.P.M. to machine.
	Restrict water flow	Check nozzle for obstruction, proper size.
<b>PUMP NOISY</b>	Air in suction line	Check water supply and connections on suction line.
	Broken or weak inlet or discharge valve springs	Check and replace if necessary.
	Excessive matter in valves	Check and clean if necessary.
	Worn bearings	Check and replace if necessary.
<b>PRESENCE OF WATER IN OIL</b>	Oil seal worn	Check and replace if necessary.
	High humidity in air	Check and change oil twice as often.
<b>WATER DRIPPING FROM UNDER PUMP</b>	Piston packing worn	Check and replace if necessary.
	O-Ring plunger retainer worn	Check and replace if necessary.
	Cracked piston	Check and replace if necessary.
	Pump protector	Lower water supply pressure. Do not run with spray gun closed longer than 2 minutes.

## TROUBLESHOOTING

PROBLEM	POSSIBLE CAUSE	SOLUTION
<b>OIL DRIPPING</b>	Oil seal worn	Check and replace if necessary.
<b>EXCESSIVE VIBRATION IN DELIVERY LINE</b>	Irregular functioning of the valves	Check and replace if necessary.
<b>DETERGENT NOT DRAWING</b>	Air leak	Tighten all clamps. Check detergent lines for holes.
	Restrictor in float tank is missing	Replace restrictor. Check for proper orifice in restrictor.
	Filter screen on detergent suction hose plugged	Clean or replace.
	Dried up detergent plugging metering valve	Disassemble and clean thoroughly.
	High viscosity of detergent	Dilute detergent to specifications.
	Hole in detergent line(s)	Repair hole.
	Low detergent level	Add detergent, if needed.
<b>PUMP RUNNING NORMALLY BUT PRESSURE LOW ON INSTALLATION</b>	Pump sucking air	Check water supply and possibility of air seepage.
	Valves sticking	Check and clean or replace if necessary.
	Nozzle incorrectly sized	Check and replace if necessary (See serial plate for proper size).
	Unloader valve seat faulty	Check and replace if necessary.
	Worn piston packing	Check and replace if necessary.
<b>BURNER MOTOR WILL NOT RUN</b>	Fuel pump seized	Replace fuel pump.
	Burner fan loose or misaligned	Position correctly, tighten set screw.
	Defective control switch	Replace switch.
	Loose wire	Check and replace or tighten wiring.
	Defective burner motor	Replace motor.
<b>RELIEF VALVE LEAKS WATER</b>	Relief valve defective	Replace or repair.

If you need **SERVICE** on your pressure washer, contact your local Hotsy dealer or visit [www.Hotsy.com](http://www.Hotsy.com). Smart phone users scan the code below to link directly to the Service Request page.



To **REGISTER** your pressure washer, please visit our Warranty Registration page at [www.hotsy.com/WarrantyRegistration.aspx](http://www.hotsy.com/WarrantyRegistration.aspx) or scan the code below with your smart phone.

