



# MODEL 555SS

## OPERATING INSTRUCTIONS AND PARTS MANUAL

*Read instructions carefully before attempting to assemble, install, operate or service this pressure washer. Failure to comply with instructions could result in personal injury and/or property damage!*

**NOTE: THIS MANUAL IS INTENDED FOR USE WITH  
THE FOLLOWING MODEL RELEASE ONLY: 555SS**

### SPECIFICATIONS

- Pump Volume At Pump Head: 2.2 GPM/132 GPH
- Burner Type: Fuel Oil Fired, 214,300 BTU/Hr.
- Burner Fuel Pressure: 200 PSI Max.
- Pump Pressure At Pump Head: 1300 PSI
- Machine Voltage: 120 VAC/60 Hz/1 Ph
- Total Machine Amperage: 20 Amps
- Machine Weight: 280 Lbs.
- Shipping Weight: 315 Lbs.
- Exhaust Stack Size: 8"
- Machine Dimensions: Length = 44", Width = 26", Height = 38"



<b>SERIAL NUMBER:</b>	
<b>DATE PURCHASED:</b>	
<b>FOR SALES AND SERVICE, PLEASE CONTACT:</b>	



# CONTENTS

Important Safety Information	4-6
Component Identification	7
Assembly Instructions	8
Installation Instructions	8-9
Operation Instructions	9-10
General Cleaning Techniques	10
Storage	11
Maintenance	11
Troubleshooting	12-13
Exploded Views	14-15
Exploded View, Parts List	16
Burner Assembly, Exploded View & Parts List	17
Burner Hotsy Crossfire Exploded View & Parts List	18-19
Coil Outlett Exploded View & Parts List	20
Fuel Tank Assembly & Parts List	20
Control Panel Assembly & Parts List	21
Water Inlet Assembly & Parts List	22
Hose, Gun & Wand Assembly & Parts List	22
Pump Assembly & Parts List	23
Pump - Exploded View & Parts List	24-25
HM DX Unloader Exploded View & Parts List	26
Wiring Diagrams	27

Model Number \_\_\_\_\_

Serial Number \_\_\_\_\_

Date of Purchase \_\_\_\_\_

The model and serial numbers will be found on a decal attached to the pressure washer. You should record both serial number and date of purchase and keep in a safe place for future reference.

# INTRODUCTION & IMPORTANT SAFETY INFORMATION

Thank you for purchasing this Pressure Washer.

We reserve the right to make changes at any time without incurring any obligation.

## Owner/User Responsibility:

The owner and/or user must have an understanding of the manufacturer's operating instructions and warnings before using this pressure washer. Warning information should be emphasized and understood. If the operator is not fluent in English, the manufacturer's instructions and warnings shall be read to and discussed with the operator in the operator's native language by the purchaser/owner, making sure that the operator comprehends its contents.

Owner and/or user must study and maintain for future reference the manufacturers' instructions.

The operator must know how to stop the machine quickly and understand the operation of all controls. Never permit anyone to operate the engine without proper instructions.

## SAVE THESE INSTRUCTIONS

This manual should be considered a permanent part of the machine and should remain with it if machine is resold.

When ordering parts, please specify model and serial number. Use only identical replacement parts.

This machine is to be used only by trained operators.

## IMPORTANT SAFETY INFORMATION

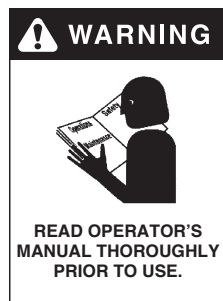

**WARNING:** To reduce the risk of injury, read operating instructions carefully before using.

1. Read the owner's manual thoroughly. Failure to follow instructions could cause malfunction of the machine and result in death, serious bodily injury and/or property damage.

2. Know how to stop the machine and bleed pressure quickly. Be thoroughly familiar with the controls.
3. Stay alert — watch what you are doing.
4. All installations must comply with local codes. Contact your electrician, plumber, utility company or the selling distributor for specific details. If your machine is rated 250 volts or less, single phase will be provided with a ground fault circuit interrupter (GFCI). If rated more than 250 volts, or more than single phase this product should only be connected to a power supply receptacle protected by a GFCI.

**DANGER:** Improper connection of the equipment-grounding conductor can result in a risk of electrocution. Check with a qualified electrician or service personnel if you are in doubt as to whether the outlet is properly grounded. Do not modify the plug provided with the product - if it will not fit the outlet, have a proper outlet installed by a qualified electrician. Do not use any type of adaptor with this product



**WARNING:** Keep wand, hose, and water spray away from electric wiring or fatal electric shock may result.

5. To protect the operator from electrical shock, the machine must be electrically grounded. It is the responsibility of the owner to connect this machine

to a UL grounded receptacle of proper voltage and amperage ratings. Do not spray water on or near electrical components. Do not touch machine with wet hands or while standing in water. Always disconnect power before servicing.



**WARNING:** Flammable liquids can create fumes which can ignite, causing property damage or severe injury.

**WARNING:** Risk of explosion — Operate only where open flame or torch is permitted.

6. In oil burning models, use only kerosene, No. 1 home heating fuel, or diesel. If diesel is used, add a soot remover to every tankful.

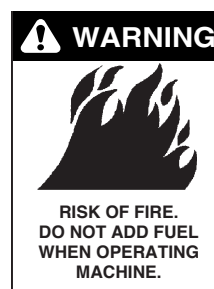

**WARNING:** Risk of fire — Do not add fuel when the product is operating or still hot.

**WARNING:** Do not use gasoline crankcase draining or oil containing gasoline, solvents or alcohol. Doing so will result in fire and/or explosion.

7. Oil burning appliances shall be installed only in locations where combustible dusts and flammable gases or vapors are not present. Do not store or use gasoline near this machine.
8. Do not allow acids, caustic or abrasive fluids to pass through the pump.
9. Never run pump dry or leave spray gun closed longer than 1-2 minutes.
10. Keep operating area clear of all persons.

# IMPORTANT SAFETY INFORMATION

**WARNING**



USE PROTECTIVE EYE WEAR AND CLOTHING WHEN OPERATING THIS EQUIPMENT.

**WARNING:** High pressure spray can cause paint chips or other particles to become airborne and fly at high speeds. To avoid personal injury, eye, hand and foot safety devices must be worn.

11. Eye, hand, and foot protection must be worn when using this equipment.

**WARNING**



RISK OF INJECTION OR SEVERE INJURY TO PERSONS. KEEP CLEAR OF NOZZLE.

**WARNING:** High pressure developed by these machines will cause personal injury or equipment damage. Keep clear of nozzle. Use caution when operating. Do not direct discharge stream at people, or severe injury or death will result.

**WARNING**



EAR PROTECTION MUST BE WORN

**WARNING:** This machine exceeds 85 db appropriate ear protection must be worn.

**WARNING**



PROTECT FROM FREEZING

**WARNING:** Protect machine from freezing.

15. To keep machine in best operating conditions, it is important you protect machine from freezing. Failure to protect machine from freezing could cause malfunction of the machine and result in death,

serious bodily injury, and/or property damage. Follow storage instructions specified in this manual.

**WARNING**



HOT DISCHARGE FLUID: DO NOT TOUCH OR DIRECT DISCHARGE STREAM AT PERSONS.

**WARNING:** Hot discharge fluid. Do not touch or direct discharge stream at persons.

**WARNING:** This machine produces hot water and must have insulated components attached to protect the operator.

16. Inlet water must be clean fresh water and no hotter than 90°F.

**WARNING**



RISK OF ASPHYXIATION: USE THIS PRODUCT ONLY IN A WELL VENTILATED AREA.

**WARNING:** Risk of asphyxiation. Use this product only in a well ventilated area.

17. Avoid installing machines in small areas or near exhaust fans. Adequate oxygen is needed for combustion or dangerous carbon monoxide will result.

**WARNING**



RISK OF INJURY: HOT SURFACES CAN CAUSE BURNS

**WARNING:** Risk of injury. Hot surfaces can cause burns. Use only designated gripping areas of spray gun and wand. Do not place hands or feet on non-insulated areas of the pressure washer.

18. Manufacturer will not be liable for any changes made to our standard machines or any components not purchased from us.

19. The best insurance against an accident is precaution and knowledge of the machine.

12. To reduce the risk of injury, close supervision is necessary when a machine is used near children. Do not allow children to operate the pressure washer. This machine must be attended during operation.

**WARNING**



RISK OF INJURY FROM FALLS WHEN USING LADDER.

**WARNING:** Be extremely careful when using a ladder, scaffolding or any other relatively unstable location. The cleaning area should have adequate slopes and drainage to reduce the possibility of a fall due to slippery surfaces.

**WARNING**



TRIGGER GUN KICKS BACK - HOLD WITH BOTH HANDS

**WARNING:** Grip cleaning wand securely with both hands before starting. Failure to do this could result in injury from a whipping wand.

13. Never make adjustments on machine while in operation.
14. Be certain all quick coupler fittings are secured before using pressure washer.

20. Do not overreach or stand on unstable support. Keep good footing and balance at all times.

21. Do not operate this machine when fatigued or under the influence of alcohol, prescription medications, or drugs.

## IMPORTANT SAFETY INFORMATION

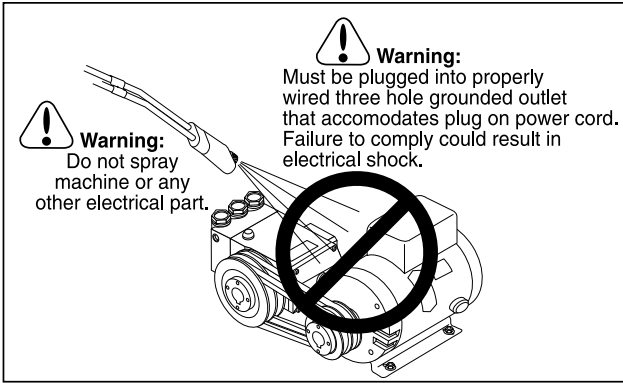

Follow the maintenance instructions specified in the manual.

## COMPONENT IDENTIFICATION

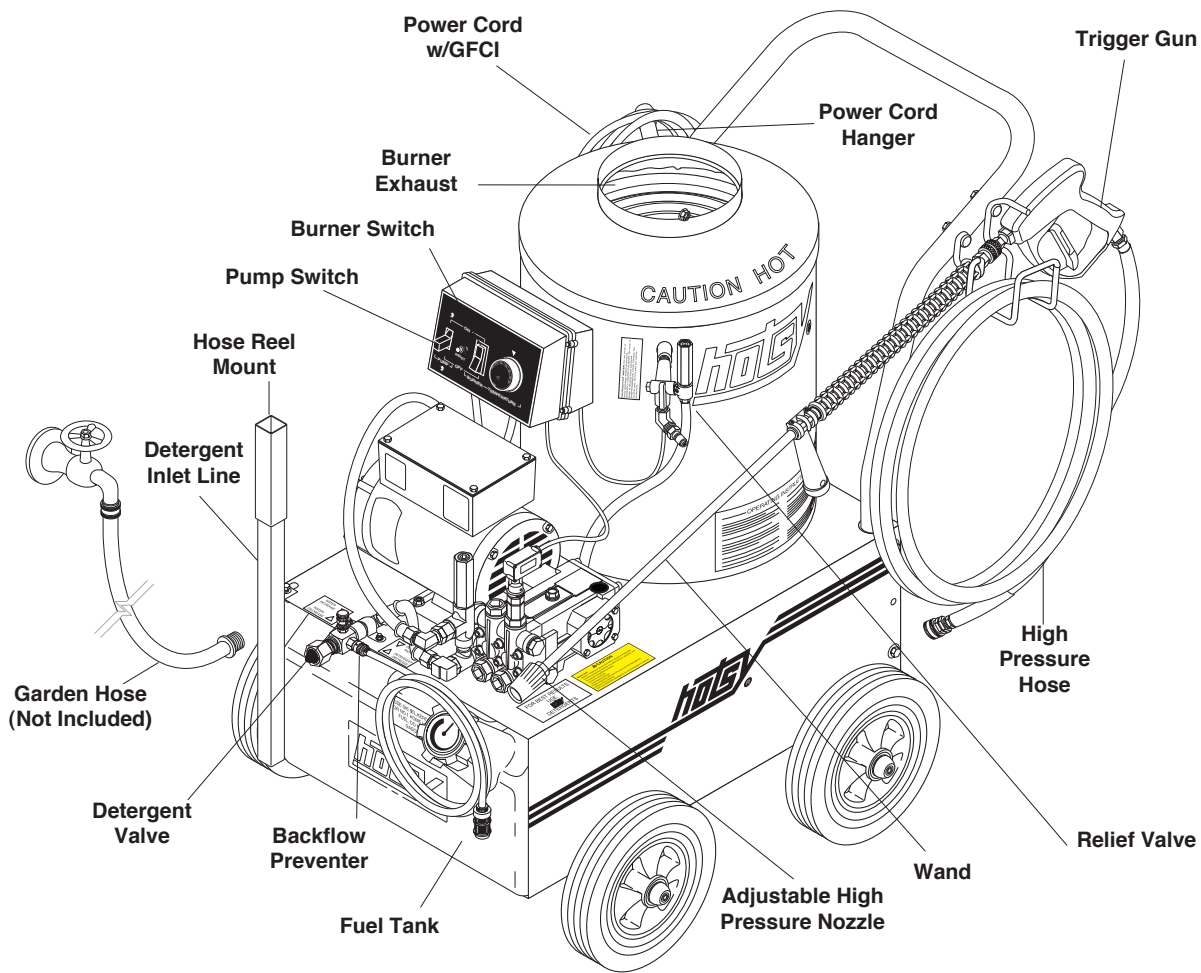

**Pump** — Delivers a specific gpm to the high pressure nozzle which develops pressure.

**Spray Gun** — Controls the application of water and detergent onto cleaning surface with trigger device. Includes safety latch.

**Detergent Valve** — Allows you to siphon and mix detergents.

**Wand** — Must be connected to the spray gun.

**High Pressure Hose** — Connect one end to water pump high pressure discharge nipple and the other end to spray gun.

**Relief valve** — Secondary pressure release in the unlikely event the unloader valve fails.

**Unloader Valve** — Safety device which, when the spray gun closes, prevents over pressurization.

# ASSEMBLY & INSTALLATION INSTRUCTIONS

## ASSEMBLY

### Unpacking

Unpack carefully. Wear safety glasses or goggles while unpacking, assembling or operating pressure washer. If there are missing components or hidden damage immediately contact distributor or carrier concerning discrepancies.

1. Cut strapping band from pressure washer and pallet.
2. Remove pressure washer from pallet.

### Parts Included

- Pressure Washer
- Pressure Hose
- Wand Assembly
- Operating Instructions and Parts Manual
- Teflon Tape

### Tools Required

- 10" Adjustable Crescent Wrench (2 ea.)

### Pressure Hose

1. When assembling, use teflon tape on all plumbing connections to prevent leakage.
2. Install high pressure hose on machine as shown in **Figure 1**.

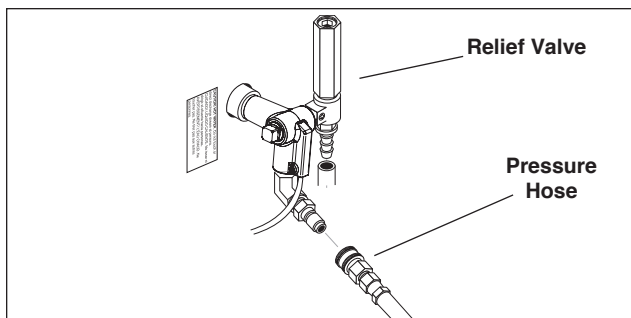

**Figure 1 - Pressure Hose Installation**

3. Assemble pressure hose onto trigger gun/wand assembly as shown in **Figure 2**.
4. Make sure that all plumbing connections are tight.

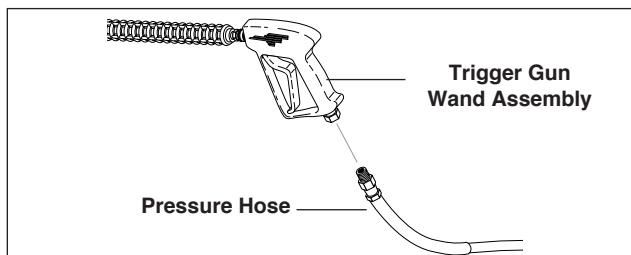

**Figure 2 - Pressure Hose Installation**

## INSTALLATION

### Getting Started

**IMPORTANT:** Proper initial installation of equipment will assure more satisfactory performance, longer service life and lower maintenance cost.

**IMPORTANT:** The use of a backflow preventer on the water supply hose is recommended and may be required by local code.

The pressure washer should be run on a level surface where it is not readily influenced by outside sources such as strong winds, freezing temperatures, rain, etc. The pressure washer should be located to assure easy access for filling of fluids, adjustments and maintenance. Normal precautions should be taken by the operator to prevent moisture from reaching the pressure washer. It is recommended that a partition be made between the wash area and the pressure washer to prevent direct spray from the wand coming in contact with the pressure washer. Moisture reaching the equipment will reduce the pressure washer's life. All installations should comply with the local codes covering such installations.

### Venting

**CAUTION:** All venting must be in accordance with applicable federal and state laws, and local ordinances. Consult local heating contractors.

If the pressure washer is to be used in an enclosed area, a flue must be installed to vent burner exhaust to the outside atmosphere. Exhaust gases should not be vented into a wall, a ceiling, or a concealed space of a building. Be sure the flue is the same size as the burner exhaust vent on the pressure washer lid. Poor draft will cause the pressure washer to soot and not operate properly. When selecting the location for installation, beware of poorly ventilated locations or areas where exhaust fans may cause an insufficient supply of oxygen. Proper combustion can only be obtained when there is a sufficient supply of oxygen available for the amount of fuel being burned. If it is necessary to install the machine in a poorly ventilated area, outside fresh air may have to be piped to the burner and a fan installed to bring sufficient air into the machine. Locate the pressure washer so that the flue will be as straight as possible and protrude through the roof at a proper height and location to provide adequate draft. This oil fired pressure washer must have a draft regulator installed in the flue (available from most heating contractors). A draft regulator will permit proper upward flow of exhaust flue gases.

# INSTALLATION & OPERATION INSTRUCTIONS

## Crossfire Oil Burner

**Burner Air Adjustment:** The oil burner on this machine is preset for operation at altitudes below 500 feet. If operated at higher altitudes, it may be necessary to adjust the air band for a #1 or #2 smoke spot on the Bacharach scale.

To adjust, start machine and turn burner ON. Loosen two locking screws found on the air band and close air band until black smoke appears from burner exhaust vent. Note air band position. Next, slowly open the air band until white smoke just starts to appear. Turn air band halfway back to the previously noted position. Tighten locking screws.

## Burner Air Adjustment

The oil burner on this machine is preset for operation at altitudes below 500 feet. If operated at higher altitudes, it may be necessary to adjust the air band for a #1 or #2 smoke spot on the Bacharach scale.

To adjust, start machine and turn burner ON. Loosen two locking screws found on the air band and close air band until black smoke appears from burner exhaust vent. Note air band position. Next, slowly open the air band until white smoke just starts to appear. Turn air band halfway back to the previously noted position.

Tighten locking screws.

For higher altitudes, the air band opening may need to be increased; for lower altitude, the .air band may need to be decreased.

For higher humidity, the air band opening may need to be increased; for lower relative humidity, the .air band may need to be decreased.

For higher ambient temperatures the air band opening may need to be increased; for lower ambient temperatures, the air band opening may need to be decreased.

Adjust to your operating location's environment as-needed for best smoke spot and performance compliant with local, state, and federal regulations.



# OPERATION INSTRUCTIONS

## OPERATION

### Before Starting

**WARNING:** Check hoses, trigger guns, fittings, and fuel connections daily for signs of wear, cracks and looseness, and replace as required.

1. Read all manuals provided with this pressure washer. Become familiar with location and function of all operating and safety controls.
2. Connect water supply hose to the standard garden hose connector. The water faucet and supply hose must be capable of providing 3.0 GPM.
3. Fill fuel tank. Use kerosene, #1 grade home heating oil, #1 or #2 diesel fuel. **DO NOT USE GASOLINE, CRANKCASE OIL RESIDUALS OR WASTE OIL.**
4. Check pump oil level.
5. If detergents are to be used, only use detergents intended for pressure washers. Follow instructions on the detergent container.

### Electrical Connections

**WARNING:** Make sure all switches and controls are in the OFF position prior to plugging in.

**CAUTION:** This pressure washer is equipped with a UL approved ground fault circuit interrupter (GFCI) power cord. Use UL grounded type receptacles of proper voltage and amperage ratings. Where a properly grounded receptacle is not available, it is the personal responsibility of the owner to have one installed. Always disconnect power before servicing your pressure washer.

Connect electrical cord and test the GFCI using the reset and test procedures provided on the GFCI device. The GFCI must be reset and tested with every use. Do not use machine if the GFCI device fails test.

### Pressure Nozzle/Trigger Lock Installation

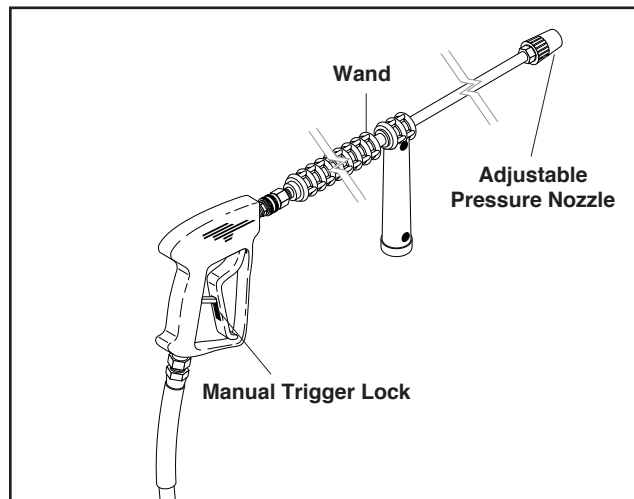

Figure 4 - Nozzle Installation/Manual Trigger Lock

**IMPORTANT:** If the pressure washer has not been used for an extended period of time, remove the nozzle from the end of the wand and turn on water supply. Allow water to run from the end of the wand until clear.

1. Install adjustable pressure nozzle on end of the wand. See Figure 4.

**IMPORTANT:** The trigger gun provided with this pressure washer is equipped with a manual trigger lock to prevent accidental operation of the trigger gun. The trigger lock should be used whenever the trigger gun is not in use.

### To Start

**IMPORTANT:** The water must be turned on before starting. Running the pump dry will cause damage to pump seals and void warranty.

**IMPORTANT:** DO NOT allow the machine to run in bypass for more than 10 minutes at any one time or damage to pump may occur.

1. Turn water on.
2. Hold gun firmly, squeeze trigger of trigger gun and turn pump switch ON. Allow air to purge from system.
3. If HOT water is desired, turn burner switch ON. Adjust thermostat to desired temperature. The burner will fire immediately with a small puff of smoke. If smoke continues refer to the **Troubleshooting Guide** in this manual. When the trigger gun is closed the burner will turn off.

### To Stop

1. If detergents were used, draw clear water through the detergent line to purge detergent.
2. If burner was used, turn off burner switch and allow pump to run cold water through coil.
3. Push OFF pump switch.
4. Turn OFF water supply.
5. Squeeze trigger gun open to relieve system pressure.

**NOTE:** If the machine is unplugged from receptacle, you must reset the GFCI power cord when machine is plugged in. Always test GFCI before each use. See instructions in the Electrical Connections section of this manual.

# OPERATION INSTRUCTIONS & CLEANING TECHNIQUES

## GENERAL CLEANING TECHNIQUES

**Warning:** Pressure washers produce a kickback. To prevent personal injuries due to falls use auxiliary safety equipment.

The detergent injector valve operates by reducing the volume of water, thus a vacuum is achieved and detergent is drawn into the system. **DO NOT** reduce the water inlet flow so much as the pump cavitates because of water starvation. Operating a pump with insufficient water will damage the pump seals.

1. Insert detergent line and screen into container of detergent.
2. Completely open detergent control knob located on the side of the detergent injector valve.
3. Start the detergent suction by rotating the water adjustment knob of the detergent injector valve. See **Figure 5**. Turning the knob counterclockwise will pull detergent into the system. The flow may be observed
4. The side control knob can now be adjusted to meter

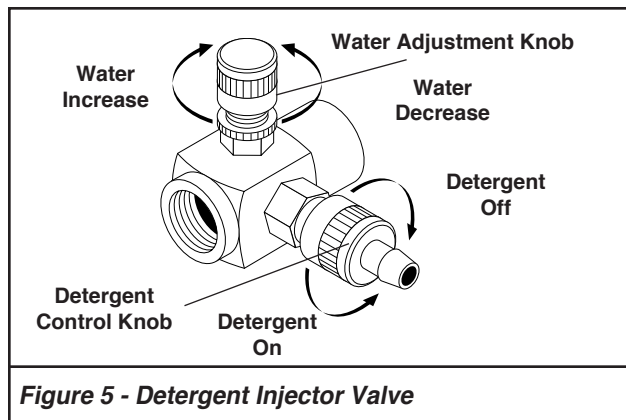

**Figure 5 - Detergent Injector Valve**

the desired amount of detergent.

5. Select the width of your nozzle spray pattern by turning the black knob on the nozzle. See **Figure 6**. Pattern can be from 0 degrees through 80 degrees fan spray. Release the trigger of the trigger gun prior to making any spray pattern adjustments.
6. Wash from the bottom to the top, using side to side

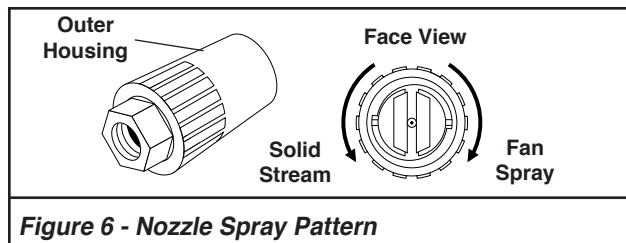

**Figure 6 - Nozzle Spray Pattern**

motions. This washes away heavy dirt and allows the detergent to soak as you work toward the top.

7. Do not wash at a 90° angle to the work (straight at it). This will allow water to splash back at you and reduces your cleaning power. Wash at a 30° to 60° angle to the work. This will allow the water to splash away from you and the water will wash the dirt away faster and easier.
8. Use the width of the spray pattern to wash in a wide path. Overlap spray paths for complete coverage washing from side to side, using slow, steady motions.
9. The nozzle should be 12" to 24" from work, closer for tough areas. Be careful on painted or delicate surfaces, the pressure may damage surface if nozzle is too close.
10. Small parts should be washed in a basket so the pressure does not push them away. Larger, lightweight parts should be clamped down so the pressure does not push them away.
11. Turn the side detergent control knob clockwise (CW) for detergent decrease. Wait for detergent to clear. Always rinse with cold water after using detergent. Rinse from the top to the bottom to prevent detergent from dripping onto a rinsed area. For the best results, contact your Hotsy dealer to help you select the best detergent for your application.

## STORAGE & MAINTENANCE

### STORAGE

#### Storage

Protect from freezing by storing in a heated area, or by flushing the system with antifreeze (use an automotive engine antifreeze or windshield washer solvent to antifreeze). To flush the system with antifreeze, attach a short length of hose to the garden hose connector located on the pump. Place the other end of the hose into a container of antifreeze. Start machine and allow to run until antifreeze flows from the end of the wand. Squeeze and release the trigger of the trigger gun several times to antifreeze the unloader system. Also draw antifreeze through the detergent inlet line to antifreeze the detergent system. For added protection after anti-freezing, disconnect the pressure hose from machine and remove the coil drain plug (refer to **Exploded View** for location). After coil has drained, replace pressure hose and coil drain plug. If the pressure washer is not to be used for an extended length of time, it is recommended that the system be flushed with antifreeze for rust protection.

### MAINTENANCE

**WARNING: Unauthorized machine modification or use of non-approved replacement parts may cause personal injury and/or property damage and will void the manufacturer warranty.**

#### Pump

**Lubrication:** To lubricate pump, use 30W non-detergent oil for pump crankcase. Crankcase must be filled to the full mark on the dipstick or to center of sight glass window found on the side of the pump, refer to **Figure 7**. During the break-in-period, make sure the oil is changed after the first 25 hours of operation. After that, replace oil every 3 months or 300 hours, whichever comes first.

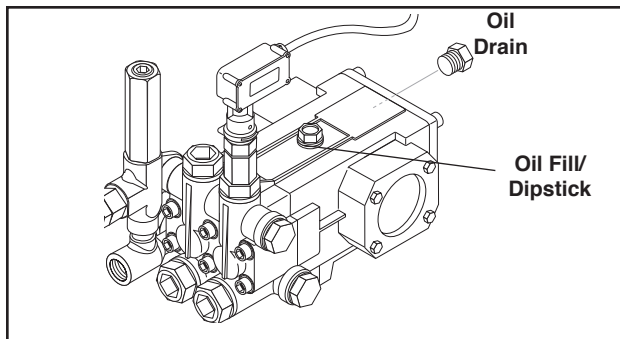

**Figure 7 - Pump Lubrication**

#### Proper Pump Care

- **DO NOT** pump acids.
- **DO NOT** allow pump to run dry.
- Winterize if storing in freezing temperatures, refer to **Storage & Maintenance** for details.
- Use a water softener on the water system if known to be high in mineral content.

- Use only high quality detergents and follow manufacturer's mix recommendations.
- Flush the system with clear water immediately after using detergent solutions.
- Clean filter screen on detergent inlet line periodically.
- Flush the pressure washer system with antifreeze if storing for an extended period of time, refer to **Storage & Maintenance** for details.

#### Pump Motor

On a yearly basis, oil pump motor per instructions on motor nameplate.

#### Unloader Valve

**WARNING: The unloader valve on this pressure washer has been factory set and sealed and is a field nonadjustable part. Tampering with the factory setting may cause personal injury and/or property damage, and will void the manufacturer warranty. For replacement parts refer to Pump Assembly.**

#### Burner Fuel Filter

Drain any water which has accumulated in fuel filter and clean or replace element as needed. For replacement parts, refer to **Burner Assembly**.

#### Heating Coil

**Coil Descaling:** In hard water areas, scale buildup within the heating coil will occur. Scale deposits will decrease the water temperature rise and may eventually clog the heating coil. Contact your local service center when descaling is needed.

**Coil Desooting:** Poor grades of fuel oil or inadequate combustion air will cause heavy soot buildup on the outside surface of the heating coil. These deposits will insulate the coil. This will restrict the air flow through the coil, further aggravating the soot buildup. Contact your local service center when desooting is needed.

#### Relief Valve

**WARNING: The relief valve on this pressure washer has been factory set and sealed and is a field non-adjustable part. Tampering with the factory setting may cause personal injury and/or property damage, and will void the manufacturer warranty. For replacement parts refer to Coil Outlet Assembly.**

If pressure from pump or thermal expansion should exceed safe limits, the relief valve will open, allowing high pressure to be discharged through hose to ground.

**Caution: Inspect relief valve annually for any obstruction.**

## TROUBLESHOOTING

SYMPTOM	POSSIBLE CAUSES	CORRECTIVE ACTION
Pump motor will not run.	GFCI tripped.	Reset and test GFCI with every use. Follow instructions on GFCI device.
	No voltage to machine.	Test power supply and correct.
	Pump motor reset switch (thermal overload protector) tripped.	Push reset switch on control box, refer to <b>Figure 1</b> . If tripped, check for proper voltage or clogged pressure nozzle.
	Excessive pressure due to clogged pressure nozzle.	Clean pressure nozzle.
Pressure washer runs but won't spray.	Trigger of trigger gun released.	Squeeze trigger.
	Water supply not turned on.	Open water supply valve.
	Clogged pressure nozzle.	Clean pressure nozzle opening.
Low spray pressure at pressure nozzle.	Inlet water screen clogged.	Check screen and clean if necessary.
	Inadequate water supply.	Fully open faucet. Check for kinked or damaged hose. Use 5/8 inch minimum hose. Check for debris clogging inlet screen.
	Partially clogged or damaged pressure nozzle.	Clean or replace.
	Air being drawn through detergent inlet line.	Refill detergent container. Ensure that pick-up screen is fully immersed.
Poor or no detergent flow.	Inadequate detergent supply.	Refill detergent container. Ensure that pick-up screen is fully immersed.
	Detergent screen or hose clogged.	Clean. Always start with a clean detergent container.
	Clogged detergent injector check valve.	Clean check valve at detergent injector inlet.
	Detergent injector not set correctly.	Refer to <b>To Clean</b> for settings.
Uneven spray pattern.	Partially clogged or damaged pressure nozzle.	Clean or replace.
Pressure washer will not produce hot water.	Burner switch in OFF position.	Place switch in ON position.
	Inadequate fuel supply.	Refill fuel tank. Use only recommended fuels. Refer to <b>Before Starting</b> under <b>Operation</b> .
	Pump switch turned off.	Pump motor must be running before burner will light.
	Inadequate water supply.	Fully open faucet. Check for kinked or damaged hose. Use 5/8 inch minimum hose. Check for debris clogging inlet screen.

## TROUBLESHOOTING

SYMPTOM	POSSIBLE CAUSES	CORRECTIVE ACTION
Pressure washer will not produce hot water.	Trigger of trigger gun released.	Squeeze trigger. Water must be spraying for burner to light.
	Defective pressure switch.	Replace pressure switch.
	Fuel valve closed.	Check that fuel valve on fuel tank is open.
	Burner motor reset button (thermal overload protector) tripped.	Push reset button on burner motor. If tripped, check for proper voltage.
	Clogged fuel filter.	Replace fuel filter.
	Thermostat set too low.	Adjust thermostat to desired temperature.
Burner smokes.	<b>AB</b> Air bands need to be adjusted.	Readjust air band per the <b>Oil Burner</b> section under <b>Installation</b> .
A) SMOKES WHILE UNIT IS RUNNING	<b>AB</b> Improper fuel.	Use proper fuel.
	<b>AB</b> Low fuel pressure < 140 PSI	Adjust fuel pump pressure to specifications.
B) SMOKES AT COLD-START WHEN BURNER IS OF	<b>AB</b> Weak fuel pump	Check fuel pump pressure. Replace pump if needed.
	<b>AB</b> Fuel filter partially clogged	Replace as needed.
	<b>AB</b> Soot build up on coils	Clean coils with soot remover
	<b>AB</b> Lime build up in coils	Clean inside of coils using Hotsy's coil cleaner.
	<b>AB</b> Improper burner nozzle	See combustion assembly breakdown.
	<b>AB</b> Electrode is misaligned	Realign electrodes to specs.
	<b>B</b> Fuel pressure is too high for clean burn (Fuel PSI above 140 but less than 200)	Reduce fuel PSI / increase air and band set for cleaner burn without max water heat loss.
Poor cleaning	Improper detergent concentration or mixing.	Mix detergent per manufacturer's instructions. Ensure that powdered detergents are fully dissolved.
	Wrong detergent for the application.	Select appropriate detergent.
	Rinsing with hot water.	A final rinse with cold water will reduce water spotting.

### IMPORTANT

If the pressure washer demonstrates other symptoms or the corrective actions listed do not correct the problem, contact the local authorized Hotsy Service Center. The Hotsy Service Center can be identified by visiting [www.hotsy.com](http://www.hotsy.com)

# EXPLODED VIEW

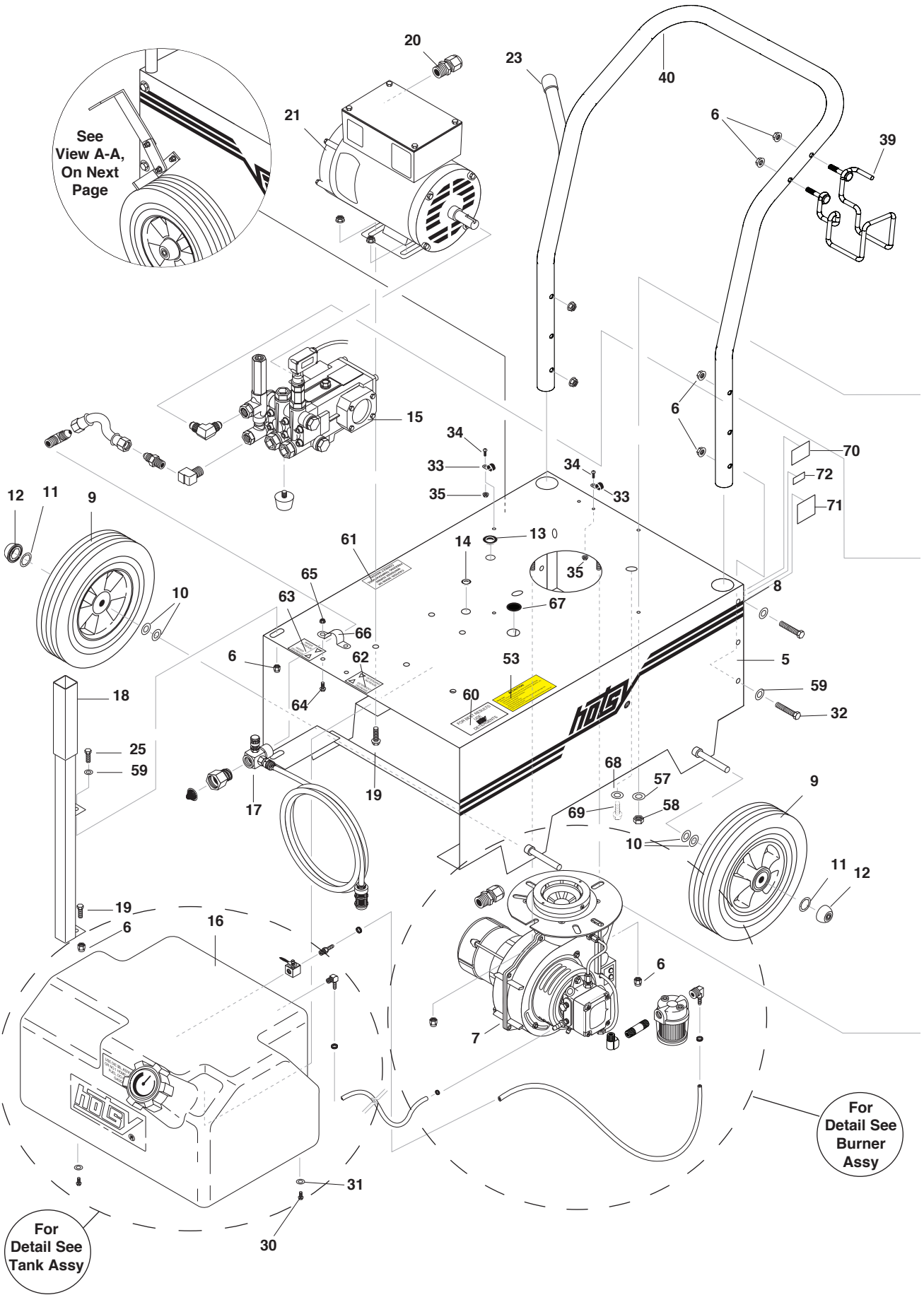

# EXPLODED VIEW

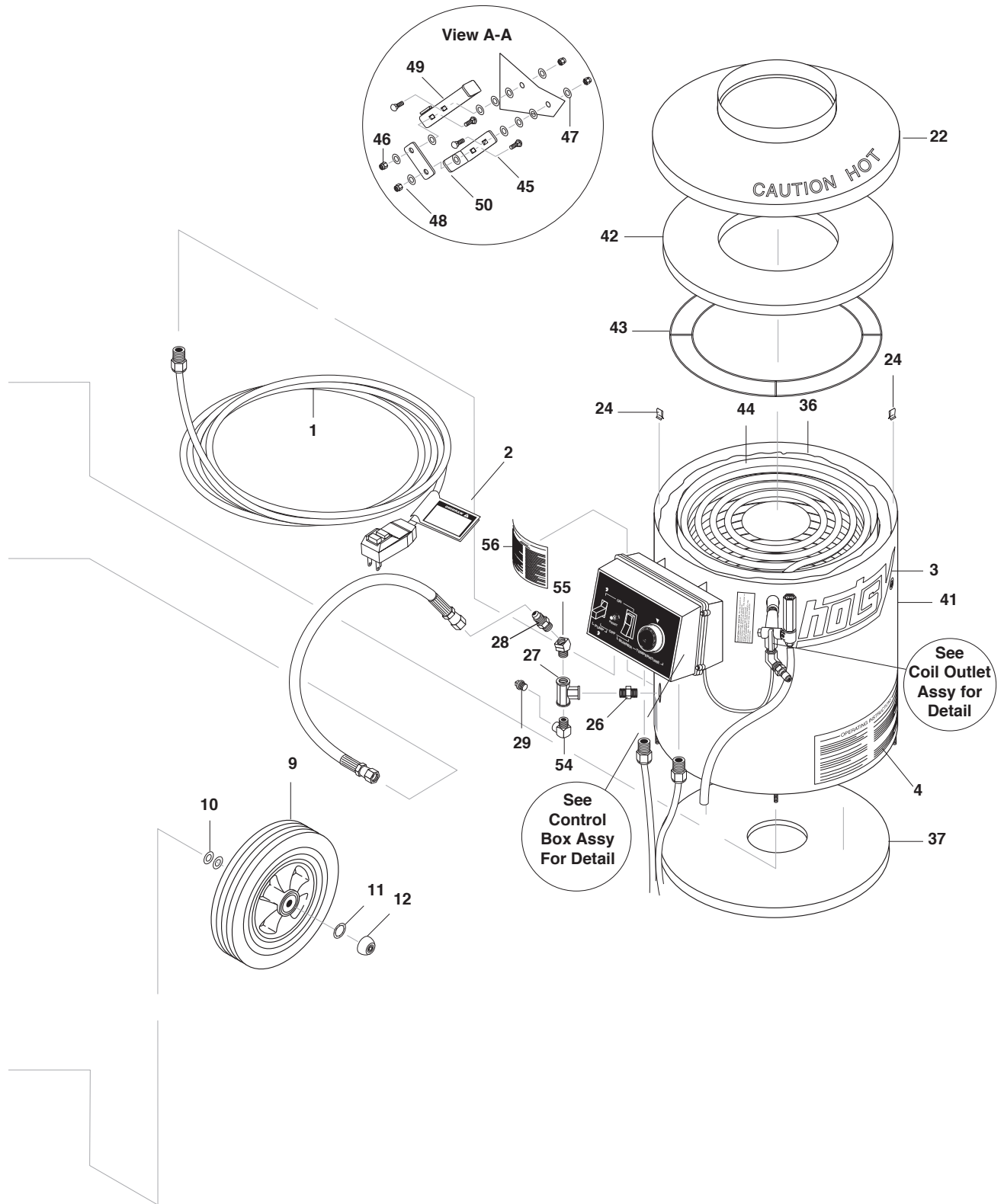

## EXPLODED VIEW PARTS LIST

ITEM	PART NO.	DESCRIPTION	QTY	ITEM	PART NO.	DESCRIPTION	QTY
1	9.802-431.0	Power Cord w/ GFCI	1	43	9.803-108.0	Ring, Insul Retainer 16" Top Hat	1
2	8.932-969.0	Label, Warning, Svc Cord	1	44	8.925-219.0	Spare Coil Hotsy 555 MTY	1
3	8.704-654.0	Label, Hotsy Logo Red	2	45	9.802-705.0	Bolt, 1/4"-20 x 1" Carriage Zinc	4
4	8.900-896.0	Label, Operating Oil Fired Electric.	1	46	9.802-773.0	Nut, 1/4-20 Esna Nc	4
5	8.911-832.0	Frame Welded Assy Hotsy 555/680/770	1	47	9.802-802.0	Washer 1/4" Flat Sae Zinc	12
6	9.802-778.0	Nut, 5/16" Whiz Loc Flange	6	48	8.912-020.0	Linkage, Brake, Red	1
7	Please See Burner Assembly Page			49	8.912-017.0	Lever, Brake, Red	1
8	8.901-106.0	Label, Hotsy Logo Stripe	2	50	8.912-019.0	Bracket, Brake Pad, Red	1
9	9.802-274.0	Wheel & Tire Hard Rubber	4	53	9.800-049.0	Label, Manufacturers Cleaning Solution	1
10	9.802-810.0	Washer 5/8" Flat Sae Zinc	8	54	8.706-207.0	Elbow, 3/8" Street 90 Deg Steel	1
11	8.718-870.0	Nut, .61 ID, Push Flat	4	55	9.802-041.0	Elbow, 3/8" Street 45 Deg Steel	1
12	9.182-506.0	Hubcap	4	56	8.704-656.0	Label, Warning, Hww Elec	1
13	9.802-104.0	Bushing, 1" Snap	1	57	9.198-014.0	Washer 21/64 x 1"	3
14	8.706-731.0	Bushing, 3/4" Snap	1	58	9.802-776.0	Nut, 5/16", Esna, Nc	3
15	Please See Pump Assembly Page			59	8.718-980.0	Washer, 5/16" Flat, Sae	3
16	Please See Fuel Tank Assembly Page			60	8.901-136.0	Label, Use Hotsy Detergent	1
17	Please See Water Inlet Assembly Page			61	8.901-135.0	Label, Caution Winterize	1
18	8.911-807.0	Bracket, Hose Reel	1	62	8.901-125.0	Label, Detergent Metering	1
19	8.718-625.0	Bolt, 5/16" x 3/4" Nc Znc	8	63	8.901-124.0	Label, Water Metering	1
20	8.752-969.0	Strain Relief, Str, Lt, 1/2 NPT	1	64	8.718-607.0	Bolt, 1/4-20 x 3/4" Carriage	2
21	8.754-709.0	Motor, 2HP, 1PH, 115V, 1750RPM 56C ODP	1	65	9.802-775.0	Nut, 1/4" Flange, Zn	2
22	8.719-913.0	Top Hat, Weld Assy, 16"	1	66	8.709-100.0	Clip, Round, 0.84 Id, Plated	1
23	8.706-698.0	Cap, 0.812 Od x 1" Vinyl Blk	1	67	8.706-744.0	Plug, Plastic 1"	1
24	9.802-825.0	Clip, Retaining U-type	4	68	9.802-819.0	Washer, 7/16" x 2 1/2", Zinc, PG Foot 3	1
25	8.718-618.0	Bolt, 5/16-18 x 3/4", Hh Znc	1	69	9.802-710.0	Screw, 5/16" x1 NC	3
26	8.705-974.0	Nipple, 3/8" Hex Steel	1	70	9.800-034.0	Label, Clear Lexan, 4.3" x 5.5"	1
27	8.706-214.0	Tee, 3/8" Female Pipe	1	71	8.930-124.0	Label, Intended For Outdoor Use - Mexico	1
28	9.802-036.0	Nipple, 1/2" Jic x 3/8" Npt	1	72	8.754-337.0	Label, ETL (RL1500), UL STD 1776, CERT	1
29	8.706-241.0	Plug, 3/8", Sq Head, Galv	1	▲ Not Shown			
30	8.718-582.0	▲ Bolt 1/4-20 x 1/2", Nc Hh	2				
31	9.802-802.0	▲ Washer 1/4" Flat Sae Znc	2				
32	9.802-716.0	Bolt, 5/16" x 2", Nc Hh	4				
33	8.709-090.0	Clamp, Wire/Tube, 0.750D	2				
34	8.718-588.0	Screw, 10-24" x 1/2", Ph	2				
35	8.718-857.0	Nut, 10/24, Whiz Loc Flange	2				
36	9.802-908.0	Insulation, Blanket, 18 x 52, Fiberglass	1				
37	9.802-903.0	Insulation, Bottom, 16 Od x 4.5, Fiberglass	1				
39	9.803-098.0	Holder	1				
40	8.920-274.0	Handle	1				
41	8.911-803.0	Wrap, Outer Coil Assy S.S., Hotsy 555	1				
42	9.802-904.0	Insulation, Top Head, 16 Od x 8 ID, Fiberglass	1				



## BURNER ASSEMBLY EXPLODED VIEW

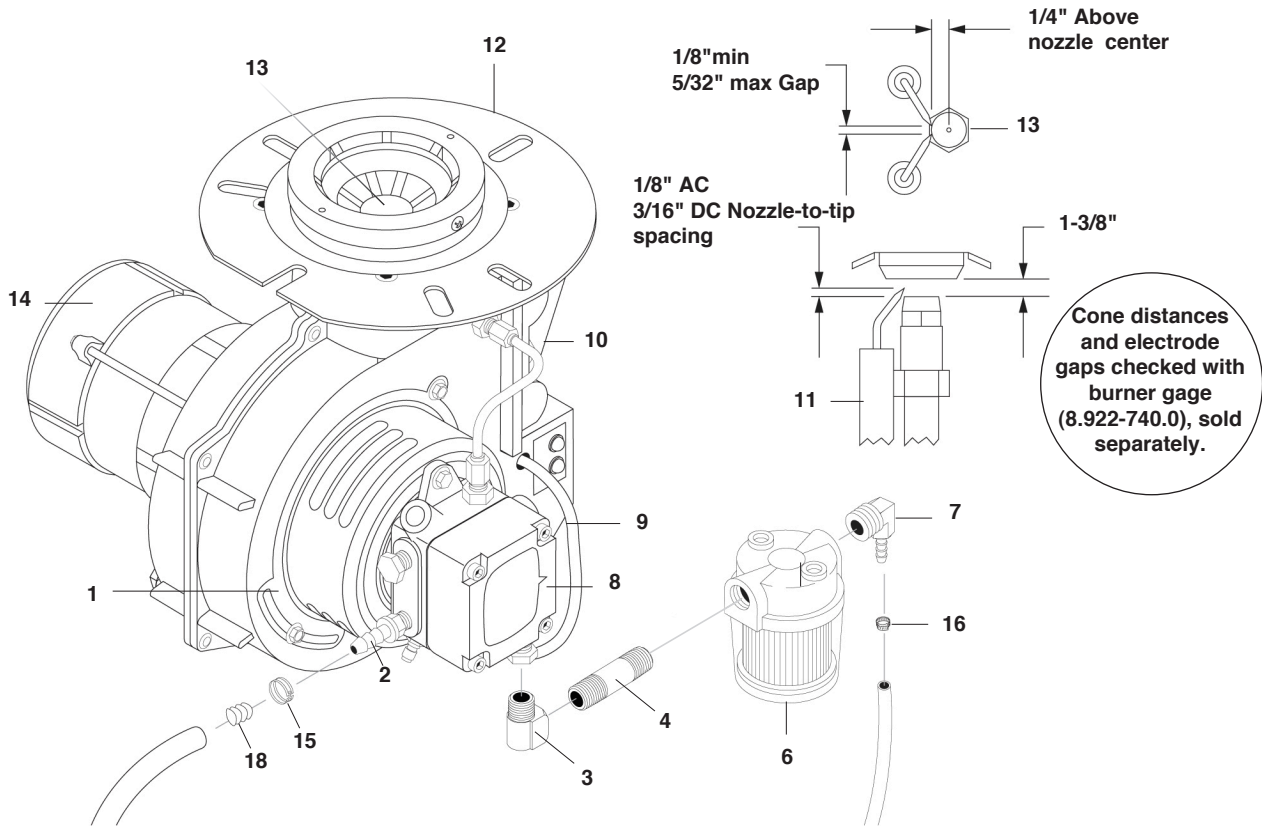

## BURNER ASSEMBLY EXPLODED VIEW PARTS LIST

ITEM	PART NO.	DESCRIPTION	QTY	ITEM	PART NO.	DESCRIPTION	QTY
1	8.756-181.0	Burner, MSR 3.75 120V 1T 120V S	1	16	8.717-711.0	▲ Screen, Fuel Filter	1
2	8.706-941.0	Hose Barb, 1/4" Barb x 1/4" Mpt, Brass	1	17	9.802-649.0	▲ Blower Wheel 4.25 x 2.5 Beckett	1
3	8.706-827.0	Elbow, 1/4" Street	1		8.750-520.0	▲ Blower Wheel Crossfire	1
4	9.803-043.0	Nipple, Pipe 1/4" x 2" Zinc Sch 80 Mpt	1	18	9.802-648.0	▲ Coupling Assy 5/16" Beckett	1
5	9.802-525.0	▲ Locknut, 1/2"	1		8.750-543.0	▲ Coupling Crossfire	1
6	8.757-652.0	Filter Fuel Hotsy 1/4" female	1	19	9.802-646.0	▲ Valve Stem Kit Cleancut Pump	1
7	8.706-958.0	Hose Barb, 1/4" Barb x 1/4" MPT, 90 DGR	1	20	9.802-666.0	▲ Screen, Fuel Pump	1
8	8.700-759.0	Fuel Pump Suntec 120V	1	21	9.802-514.0	▲ Strain Relief, Lt, Str, 1/2 Npt, .23-.45 D	1
9	9.802-640.0	Fuel Solenoid	1			▲ Not Shown	
10	8.919-114.0	Ignitor, 120V Crossfire	1				
11	8.750-778.0	Electrode Crossfire	1				
12	9.802-655.0	Air Cone, F-6	1				
13	8.756-179.0	Fuel Nozzle 1.35 x 80 BZ	1				
14	8.750-517.0	Motor, 120V Crossfire	1				
15	6.390-126.0	Clamp Hose, Uni .46-.54	1				
16	8.750-933.0	Band Hose Clamp, Hose Id 1/8" - 5/16"	1				
17	8.754-911.0	Check Valve, 1 way, 1/4"	1				

# WAYNE BURNER EXPLODED VIEW

## Replacement Parts

For best performance specify genuine WAYNE replacement parts

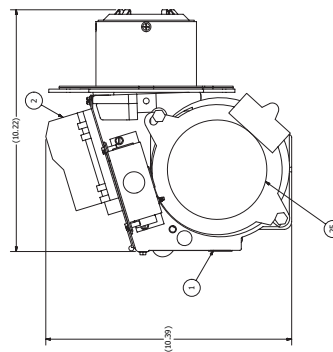
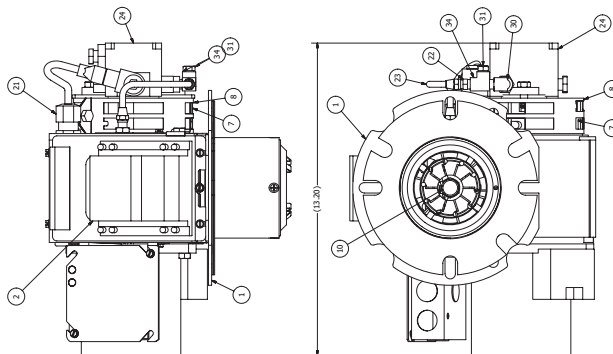
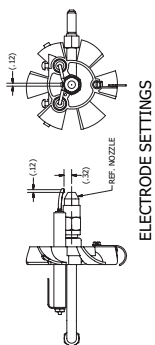

ASSEMBLED VIEWS

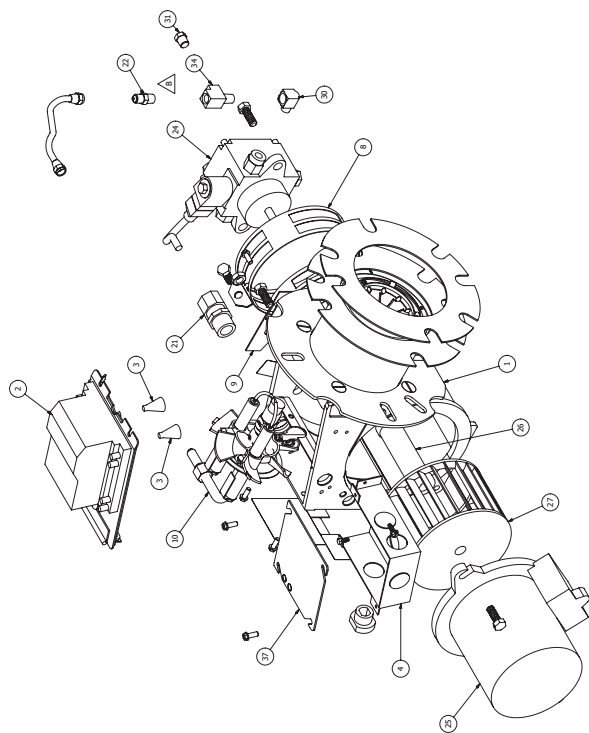

EXPLODED VIEW

## WAYNE BURNER PART LIST

### Replacement Parts

*For best performance specify genuine WAYNE replacement parts*

ITEM	PART NO.	DESCRIPTION	QTY
1	101397-001	Tube/Hous-101392-001/ 5A/3.5"/3"l	1
2	101295-002	Ignitor- D W/M Plate 120V	1
3	100990-001	Spring, Contact	1
4	8.756-740.0	Junction Box, MSR, Black Body	1
7	8.700-707.0	Air Band Inner "M"	1
8	20602-002	Band, Air Outer 8-Hole Mod M	1
9	13392	Plate, Slot Cover	1
10	8.756-298.0	Gun Assembly, Burner-RG/*CST/*1 1/4"BB1	1
19	11141	Decal, UL-Under 3 GPH Non C57	1
21	31954-001	Strain Relief-Low Profile	1
22	14222	Connector, Male-3/16" x 1/8" IPT	1
23	8.700-704.0	Oil Line Assembly 6"	1
24	8.756-290.0	Pump - Combo/W Solenoid 120V	1
25	8.756-292.0	Motor 1/7 HP 120/60	1
26	8.700-822.0	Coupling "M"	1
27	8.700-726.0	Fan - 3.12" x 4.25"D 1/2" Bore	1
30	550053	Fitting, Elbow 90* Street 1/8	1
31	15766	Plug, Pipe HXHD 1/8" NPT	1
34	101274-001	Tee, Street-1/8 X 1/8 Brass	1
35	12407	Stopper, #4 Cork	1
36	8.700-692.0	Flange Gasket (2 Each)	2
37	8.756-739.0	Junction Box, MSR, Black Cover	1

## COIL OUTLET ASSEMBLY EXPLODED VIEW & PARTS LIST

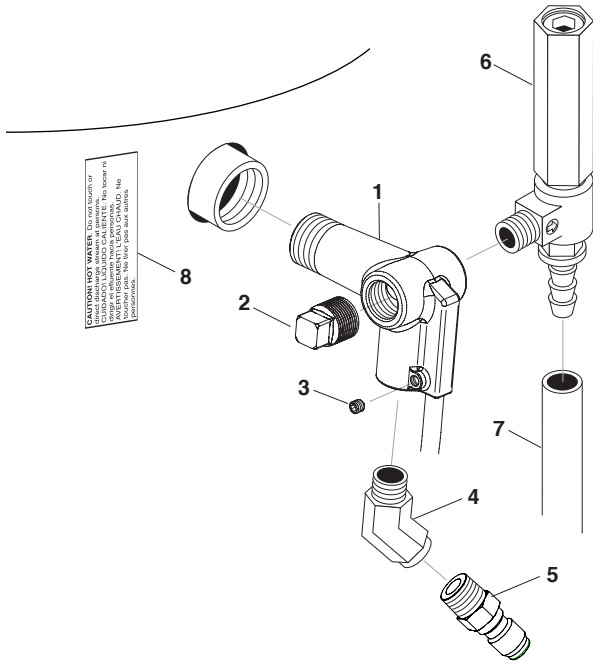

ITEM	PART NO.	DESCRIPTION	QTY
1	9.149-003.0	Manifold Coil Outlet Discharge	1
2	8.706-241.0	Plug, 3/8" Sq Head, Galv	1
3	9.196-012.0	Screw, 10-24 x 1/4" Hex Set 1	
4	9.802-041.0	Elbow, 3/8" Street 45 Deg Steel	1
5	9.802-171.0	Coupler, 3/8" Plug, Male Steel / Zinc	1
6	8.902-433.0	Valve, Safety Relief VSA	1
7	8.711-785.0	Hose, 3/8" Push On, 28" Per Ft	
8	9.800-021.0	Label, Hot Water Outlet	1

## FUEL TANK ASSEMBLY EXPLODED VIEW & PARTS LIST

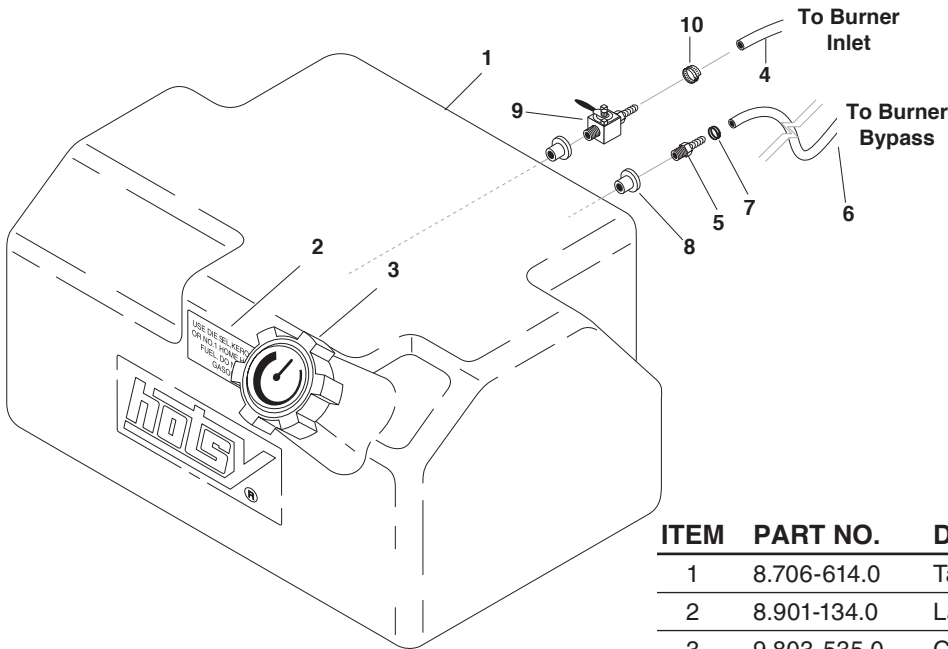

ITEM	PART NO.	DESCRIPTION	QTY
1	8.706-614.0	Tank, Fuel, 8 Gal Hotsy	1
2	8.901-134.0	Label, Fuel Type	1
3	9.803-535.0	Cap With Fuel Display 14"	1
4	9.802-254.0	Hose 1/4" x 20" Push-On, 21" Fuel Line	
5	9.802-141.0	Hose Barb, 1/4" Barb x 3/8" 1 Barb, Dou	
6	9.802-254.0	Hose, 1/4" Push-On, Ft	15"
7	6.390-126.0	Clamp, Hose, .46-.54 St	1
8	9.802-053.0	Bushing, Fuel Line, Rubber	2
9	9.802-177.0	Valve, 1/4" Shut Off, 180 Deg	1
10	8.750-933.0	Band Hose Clamp, Hose id 1/8"- 5/16"	1

# CONTROL PANEL ASSEMBLY EXPLODED VIEW

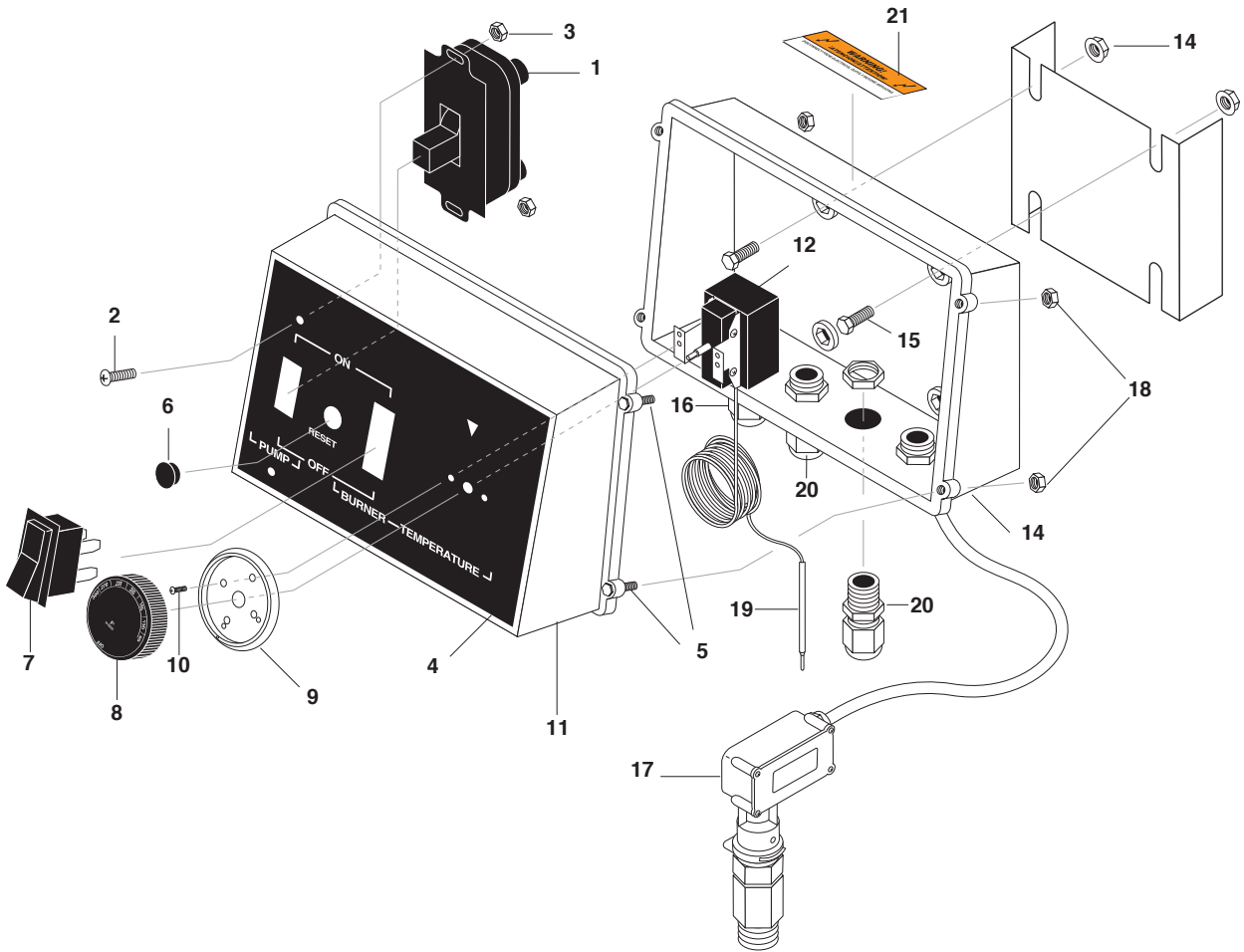

## CONTROL PANEL EXPLODED VIEW PARTS LIST

ITEM	PART NO.	DESCRIPTION	QTY	ITEM	PART NO.	DESCRIPTION	QTY
1	8.716-053.0	Switch, Toggle, 40A/230V	1	17	8.716-125.0	Switch, Pressure 3/8" NPT Brass, 65"	1
2	8.718-569.0	Screw, 10-32 x 1/2"	2	18	9.803-250.0	Nut, (Electrical Box)	4
3	9.804-567.0	Nut, 10/32" Esna	2	19	9.804-072.0	Conduit, Wire Cover, 1000/Bx	17"
4	8.901-142.0	Label, Control Box	1	20	8.752-969.0	Strain Relief, LT, STR, 1/2 NPT	2
5	9.803-249.0	Screw, M4 x 10	4	21	9.800-016.0	Label, Disconnect Power Supply	1
6	8.706-741.0	Plug, Plastic 7/16"	1	<b>REPLACEMENT PARTS</b>			
7	8.716-055.0	Switch, Rocker, 10A/250V	1		8.717-667.0	O-Ring Kit	1
8	8.750-097.0	Knob, Thermostat	1		8.717-256.0	Switch	1
9	8.712-190.0	Bezel, Plastic, Thermostat	1				
10	8.718-779.0	Screw, 4mm x 6mm, Pan	2				
11	8.716-282.0	Box Plastic Front 1 Sq Hole	1				
12	8.750-095.0	Thermostat, 120C/240F 2 Meter Capillary	1				
13	9.802-480.0	Back Box	1				
14	9.802-775.0	Nut, 1/4" Flange, Zn	4				
15	9.802-700.0	Bolt, 1/4-20 x 3/4" Nc Hh	4				
16	9.802-514.0	Strain Relief, Lt, Str, 1/2 Npt, .23-.45D	2				

## WATER INLET ASSEMBLY EXPLODED VIEW & PARTS LIST

ITEM	PART NO.	DESCRIPTION	QTY
1	9.802-147.0	Swivel, 3/8" Mp x 3/4" Ghf W/ Strainer	1
2	9.803-275.0	Injector, Adjustable, Inlet Hotsy	1
3	8.706-828.0	Elbow, 3/8" Streer, 90 Dgr	1
4	8.706-944.0	Hose Barb, 3/8" Barb x 3/8" 1 MI Pipe	1
5	8.711-785.0	Hose, 3/8" Push On, Per Ft	8.5"
6	6.390-126.0	Clamp, Hose, .46-.54 St	2
7	9.802-252.0	Hose, 1/4" x 1/2", Braided Vinyl /Ft	48"
8	8.707-057.0	Strainer, Plastic, 1/4" Hose Barb	1

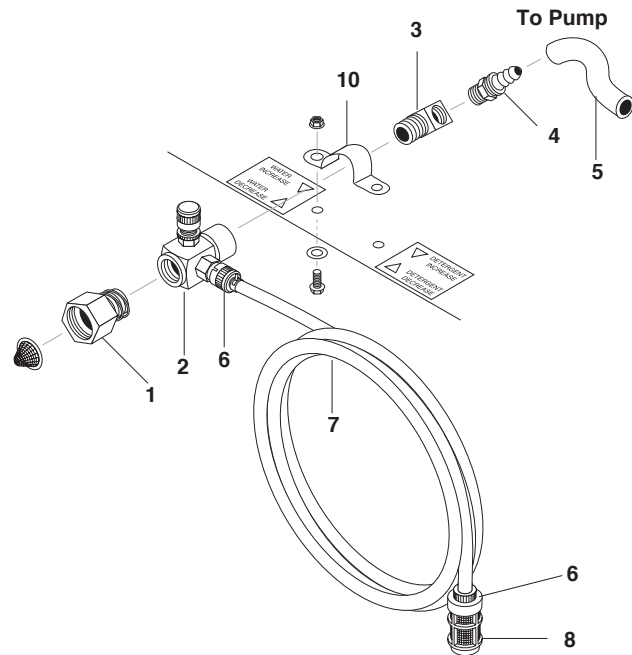

## HOSE, GUN & WAND ASSEMBLY & PARTS LIST

ITEM	PART NO.	DESCRIPTION	QTY
1	8.712-401.0	Nozzle, Variable Fan	1
2	8.725-389.0	★ Wand, Single, 36", Insulated W/ Side Grip	1
3	9.802-164.0	Coupler, 1/4" Socket, Female, Brass	1
4	8.707-139.0	Coupler, 1/4" Plug, Male Steel / Zinc	1
5	8.751-235.0	Gun, Hotsy, H1050, 5000 PSI, 10.4 Gpm	1
6	8.925-130.0	Hose, 3/8" X 50' 1W 4000PSI SW/SO/CPL	1

### REPLACEMENT PARTS

★	8.717-661.0	Grip, Handle Assy Hotsy	1
★	8.706-670.0	Grip, Wand Side Handle	1
	8.751-119.0	Kit, Gun Repair	1

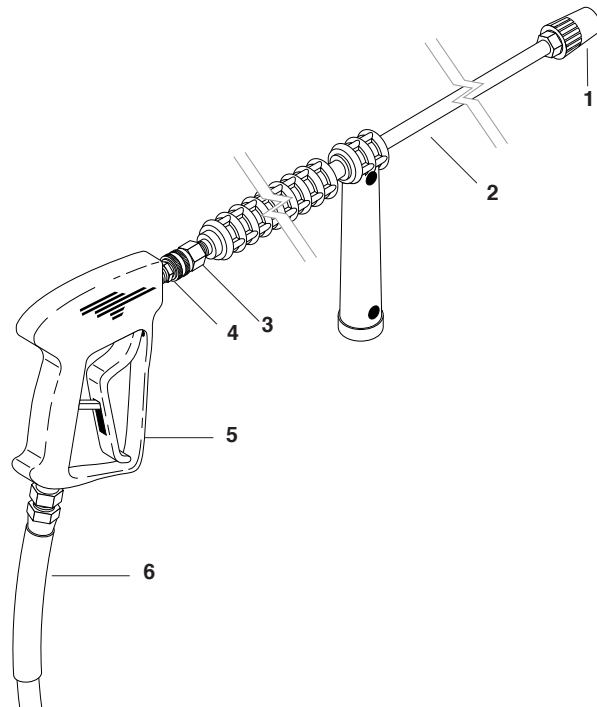

## PUMP ASSEMBLY EXPLODED VIEW

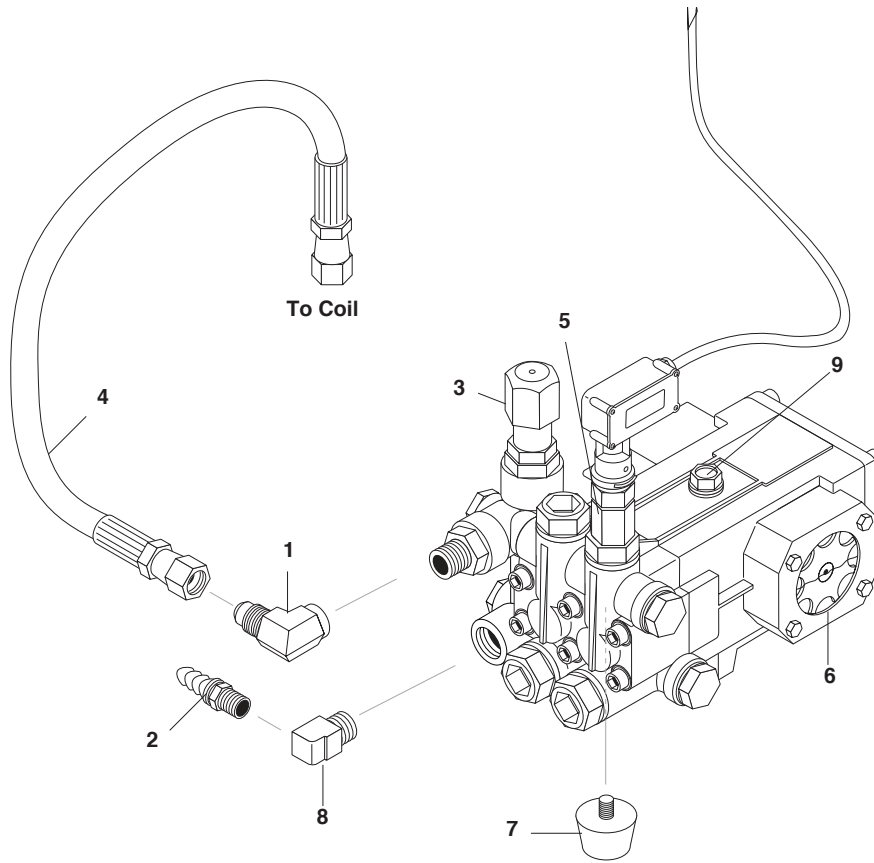

### PUMP EXPLODED VIEW PARTS LIST

ITEM	PART NO.	DESCRIPTION	QTY
1	9.802-042.0	Elbow, 1/2 JIC X 3/8 FEM, 90DGR	1
2	8.706-944.0	Hose Barb, 3/8" Barb x 3/8" ML Pipe	1
3	8.715-502.0	Unloader, HM DX Unset (921462)	1
4	8.918-424.0	Hose, 3/8" x 25", 2 Wire Pres Loop	1
5	8.707-264.0	Plug, 3/8" Gas Tap	1
6	8.904-909.0	Pump, Hotsy HHC165L.1, 2.2@1450 1740 Rpm	1
7	8.706-513.0	Mount, Vib, Neo, M8x1.25Met 5/8 St 1-1	1
8	8.706-828.0	Elbow, 3/8" Street, 90 Dgr	1
9	9.803-957.0	Oil Dipstick	1
<b>REPLACEMENT PARTS</b>			
⊛	8.717-673.0	Kit, Discharge, Unloader VBA	1
⊛	8.717-672.0	Kit, O-Ring, Unloader, VBA	1
⊛	8.717-674.0	Kit, Stem, Unloader, VBA	1

# DUPLEX SERIES PUMP

8.904-909.0 HHC165L.1

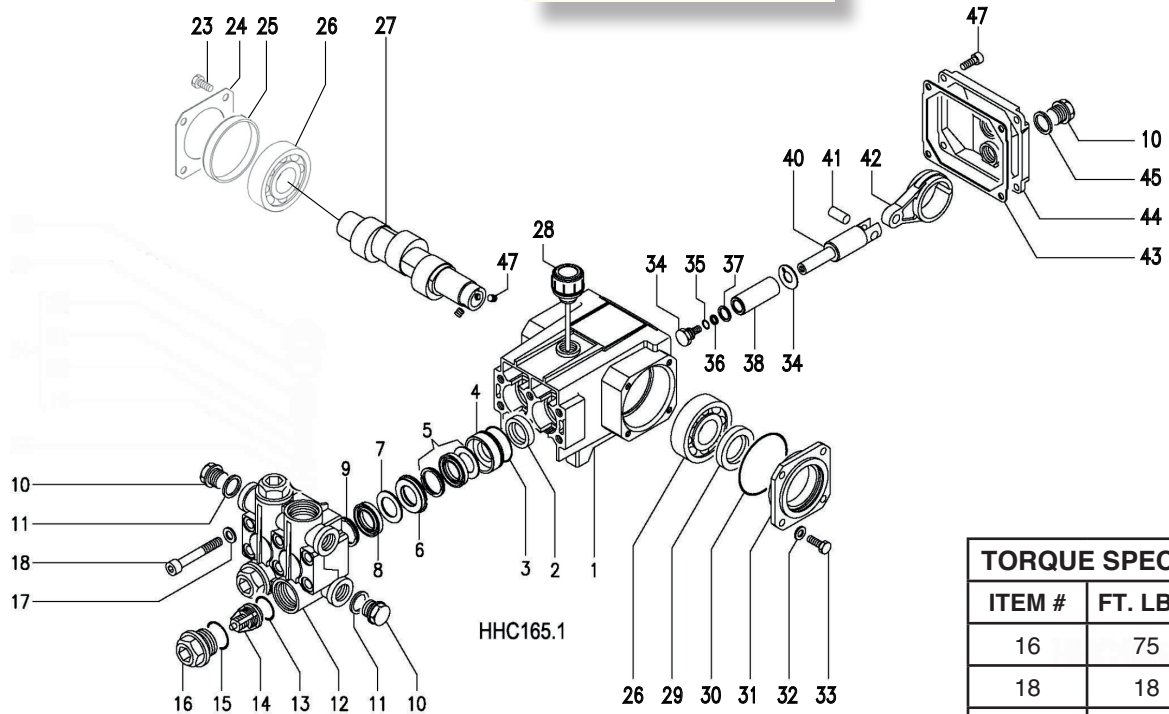

TORQUE SPECS	
ITEM #	FT. LBS.
16	75
18	18
23	7.6
34	7.6
35	4.5
47	7.6

# DUPLEX SERIES PUMP

ITEM	PART NO.	DESCRIPTION	QTY
1	8.717-123.0	Crankcase	1
2*	See Kit Below	Plunger Seal	2
3*	See Kit Below	O-Ring, Pressure Ring	2
4*	See Kit Below	Pressure Ring 20mm	2
5*	See Kit Below	U-Seal, 20mm	4
6*	See Kit Below	Intermediate Ring	2
7*	See Kit Below	Back Ring	2
8*	See Kit Below	U-Seal, 20mm	2
9*	See Kit Below	Support Ring, 20mm	2
10	9.802-925.0	Plug, 3/8"	3
11	9.803-198.0	Copper Washer	2
12	8.717-507.0	Manifold	1
13*	See Kit Below	O-Ring Valve Seat	4
14*	See Kit Below	Valve Assembly	4
15*	See Kit Below	O-Ring Manifold Plug	4
16	9.802-924.0	Plug Manifold	4
17	9.802-884.0	Washer	6

ITEM	PART NO.	DESCRIPTION	QTY
18	9.803-952.0	Manifold Stud Bolt	6
23	8.717-540.0	Screw, Hex 6mm	4
24	9.803-953.0	Cover, Side Bearing	1
25	9.853-170.0	Bearing Seal	1
26	9.803-955.0	Bearing	2
27	8.717-060.0	Crankshaft, HHC165	1
28	9.803-957.0	Oil Dipstick	1
29	8.717.020-0	Seal, Crankshaft	1
30	8.717-225.0	O-Ring, Bearing Housing	1
31	8.717-196.0	Bearing Housing	1
32	8.718-974.0	Washer	4
33	8.717-539.0	Screw, Hex	4
34*	See Kit Below	Bolt, Plunger Assy	2
35*	See Kit Below	O-Ring, Plunger Bolt	2
36*	See Kit Below	Teflon Ring	2
37*	See Kit Below	Spacer, Copper	2
38*	See Kit Below	Ceramic Piston, 20mm	2



## DUPLEX SERIES PUMP

ITEM	PART NO.	DESCRIPTION	QTY
39*	See Kit Below	Spacer, Copper	2
40	8.717-042.0	Plunger Rod	2
41	9.802-917.0	Connecting Rod Pin	2
42	8.717-111.0	Connecting Rod Assy	2
43	8.717-215.0	Gasket, Crankshaft Cover	1
44	8.717-136.0	Cover, Crankcase	1
45	8.707-267.0	Gasket	1
46	9.802-939.0	Screw, Allen Crankcase	4
47	9.802-945.0	Screw, Set 6mm	2

\* Available in kit (See below)

KIT NUMBERS	8.750-001.0	8.725-408.0	8.717-584.0	8.717-587.0	8.717-670.0
KIT DESCRIPTION	Seal Packing 20mm, 2 Cyl HHC165	Complete Seal Packing HHC165	Complete Valve Assy.	Plunger Seal 2 Cyl	Ceramic Piston
ITEMS NUMBERS INCLUDED	3, 5, 7, 8, 9	3, 4, 5, 6, 7, 8, 9	13, 14, 15	2	34, 35, 36, 37, 38, 39
NO. OF CYLINDERS KIT WILL SERVICE	2	1	1	2	1

## HM DX UNLOADER EXPLODED VIEW

8.715-502.0

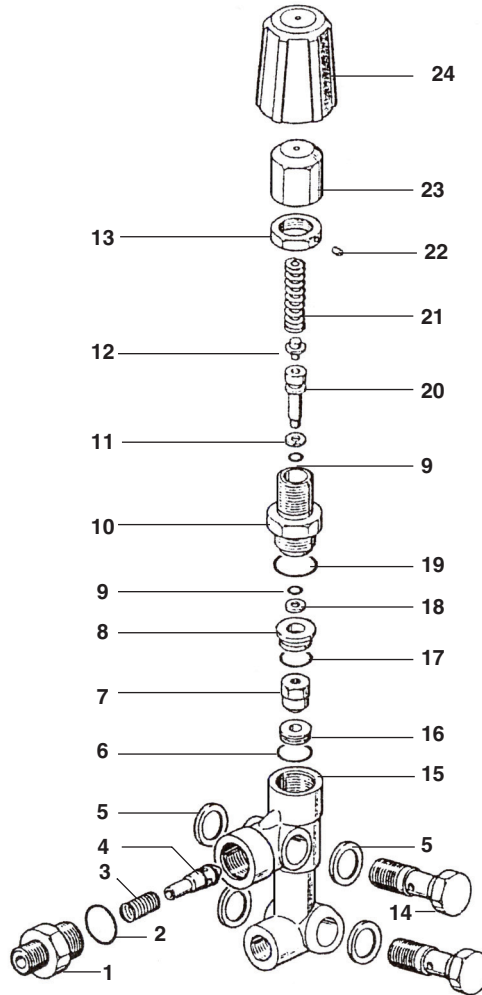

### HM DX UNLOADER EXPLODED VIEW PARTS LIST

ITEM	PART #	DESCRIPTION	KIT	QTY	ITEM	PART #	DESCRIPTION	KIT	QTY
1	9.802-892.0	Outlet Connector		1	15	8.730-841.0	Body ST-MT		1
2	70-050199	O-Ring 3068	A, B	1		8.730-842.0	Body	D	1
3	9.803-191.0	Spring	B	1		8.730-843.0	Body SST		1
4	9.803-917.0	Poppet	B	1	16	9.803-904.0	Seat	C	1
5	9.802-893.0	Seal Washer 3/8		4	17	9.803-906.0	O-Ring 2056	A	1
6	8.730-863.0	O-Ring 2050	A, C	1	18	9.803-908.0	O-Ring, Teflon	A	1
7	70-450400	Ball, Sub Assembly		1	19	70-060462	O-Ring 3081	A	1
8	9.803-907.0	Guide Bushing		1	20	9.803-913.0	Stem	C	1
9	9.803-909.0	O-Ring 108	A	2	21	8.730-870.0	Spring	C	1
10	8.730-882.0	Connector		1	22	8.933-021.0	Screw, Set		1
11	9.803-912.0	O-Ring, Teflon	A	1	23	8.730-871.0	Knob, Brass		1
12	8.932-694.0	Plate	C	1	24	70-090513	Knob, Plastic Blue (1000 psi)		1
13	9.803-925.0	Nut, 20 mm x 1.5 mm		1		70-090514	Knob, Plastic, Green (1500 psi)		1
14	9.803-919.0	Banjo Bolt, 3/8		2		70-090515	Knob, Plastic, Yellow (2200 psi)		1
						8.717-270.0	Knob, Plastic, Red (3000 psi)		1
					<b>Kit A</b>	8.717-672.0	O-Ring Repair Kit		
					<b>Kit B</b>	8.717-673.0	Outlet Kit		
					<b>Kit C</b>	8.717-674.0	Stem Repair Kit		

# WIRING DIAGRAM

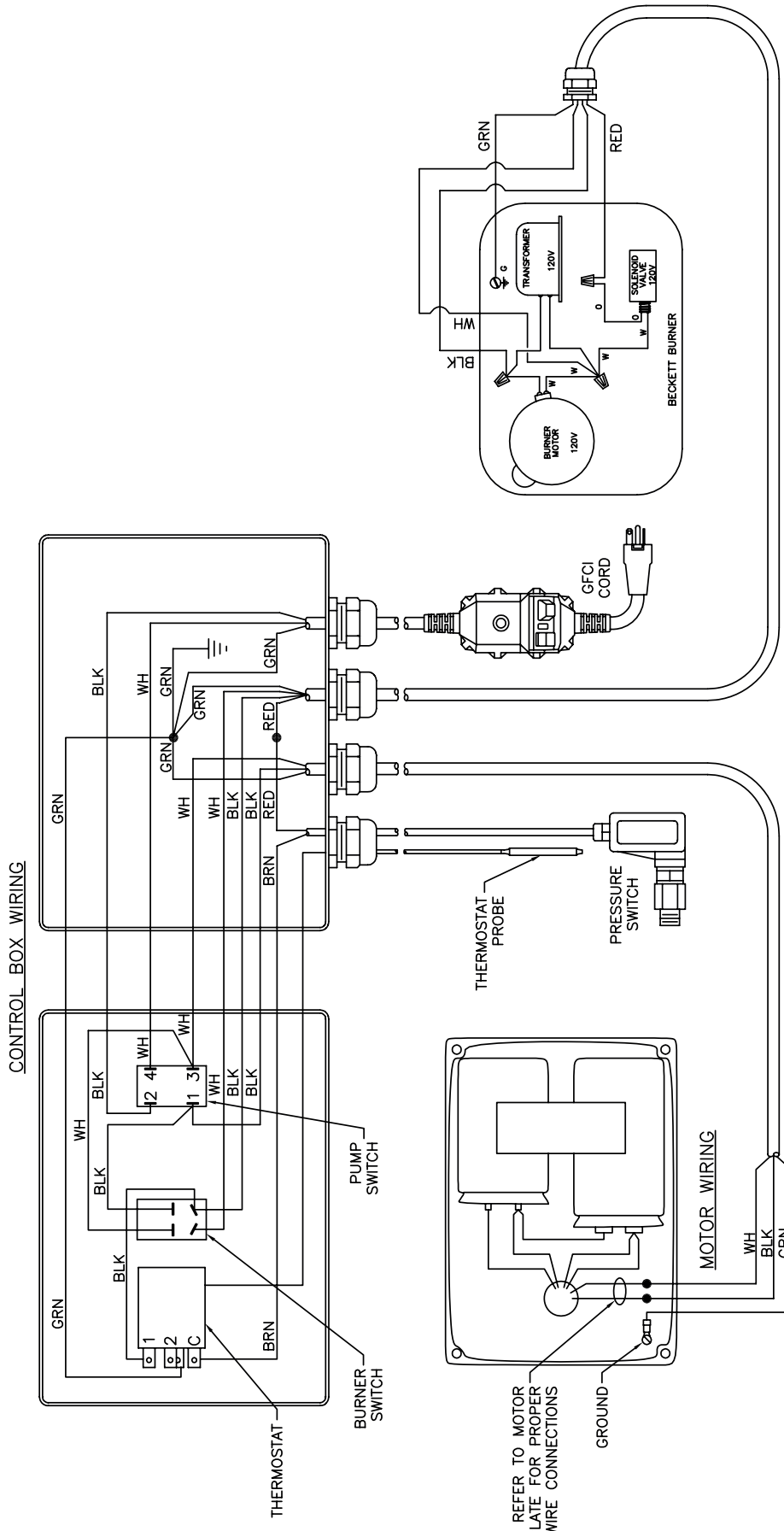





If you need **SERVICE** on your pressure washer, contact your local Hotsy dealer or visit [www.Hotsy.com](http://www.Hotsy.com). Smart phone users scan the code below to link directly to the Service Request page.



To **REGISTER** your pressure washer, please visit our Warranty Registration page at [www.hotsy.com/WarrantyRegistration.aspx](http://www.hotsy.com/WarrantyRegistration.aspx) or scan the code below with your smart phone.

